

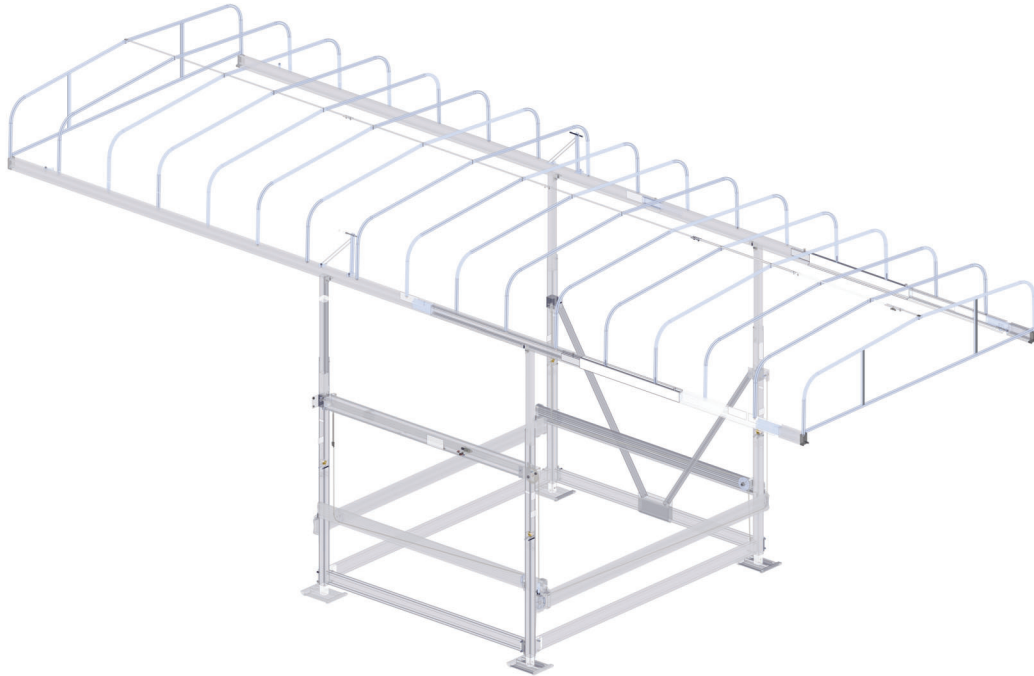

# INSTALLATION INSTRUCTIONS

## CANOPY FRAME 4' ADD-ON KIT

P/N 512-00008-00



For more information, go to the owner support tab on the FLOE website

\*LIFT, CANOPY FRAME, AND CANOPY HOOPS NOT INCLUDED

### TOOLS REQUIRED

- 7/16" SOCKET/WRENCH
- 3/4" SOCKET/WRENCH
  - TAPE MEASURE
  - TORQUE WRENCH

# BILL OF MATERIALS/EXPLODED VIEW

P/N 512-00008-00	KIT, CANOPY FRAME ADD ON, ADDS 4'		
NUMBER	PART NUMBER	QTY	DESCRIPTION
1	001-74420-00	2	CB, 1/4-20 X 1" SS 18-8
2	001-74422-00	2	CB, 1/4-20 X 1-1/2" SS 18-8
3	001-75001-00	4	NYLOCK, 1/4-20 ALUM.
4	002-04470-00	1	RAIL, CANOPY CENTER - 48"
5	002-04520-00	1	SPLICE CHANNEL (4") CTR RAIL
6	006-10603-00	4	TUBE, 1/2" VINYL - 2"
7	112-00162-00	1	ASS'Y, 48" MAIN W/ SPLICE (A)
8	112-00163-00	1	ASS'Y, 48" MAIN W/ SPLICE (B)

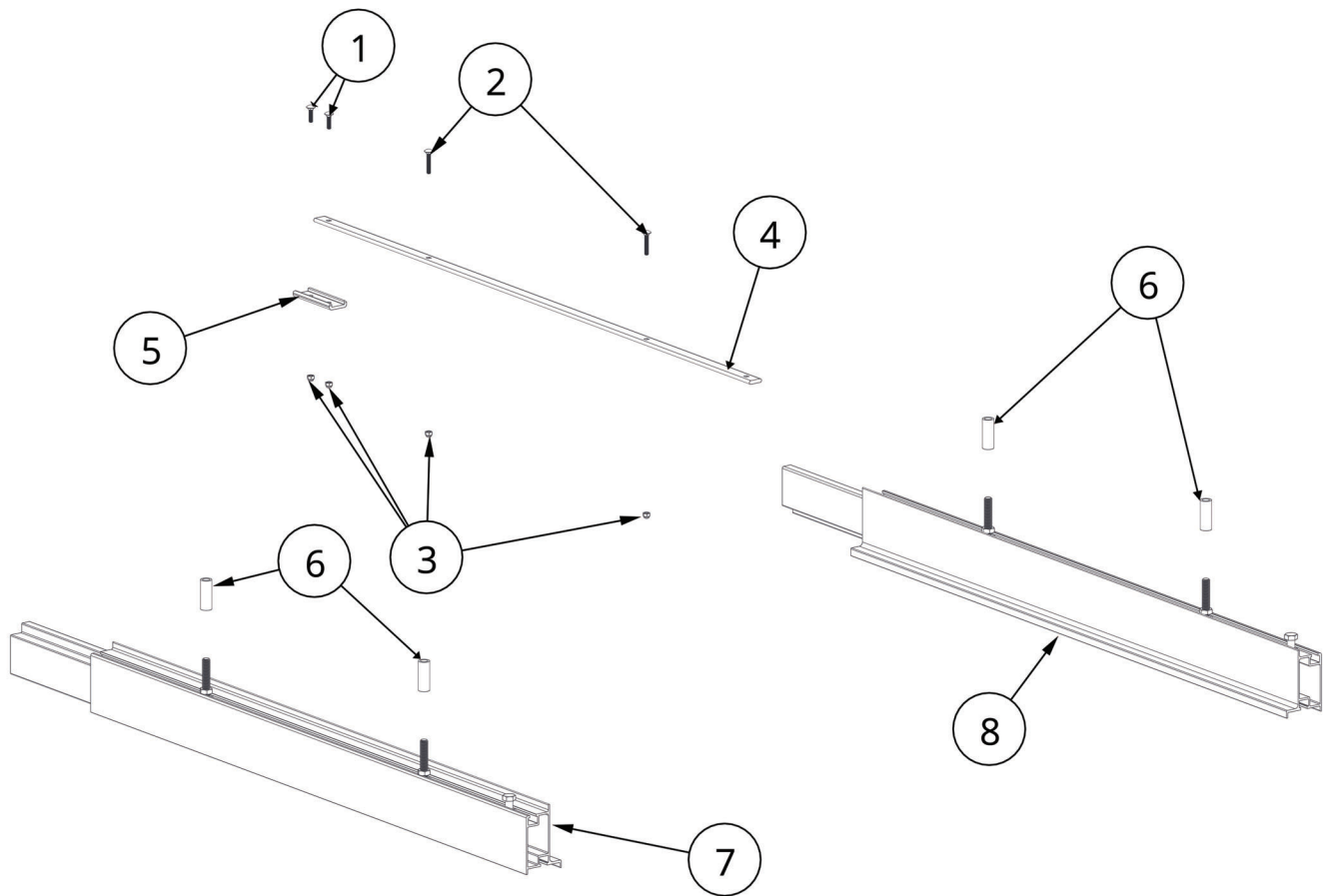

# INSTALLATION

FOR THESE INSTRUCTIONS, A 10.5' X 28' STANDARD CANOPY IS SHOWN. THE INSTALLATION PROCESS IS SIMILAR TO ALL CANOPIES, WHERE THE INCLUDED 48" MAIN RAIL WILL BE INSTALLED ONTO THE ADJUSTING MAIN RAILS AND CONNECTED TO THE REST OF THE MAIN RAILS.

IF THE CANOPY HAS BEEN INSTALLED ONTO THE FRAME, RETRACT THE ADJUSTING RAILS AND CENTER RAIL FULLY, UNATTACH THE VELCRO AND CLIPS FROM THE FRAME, THEN PULL THE CANOPY UP AND ROLL IT OVER THE TOP OF THE HOOPS ON THE ADJUSTING END OF THE CANOPY. CONTINUE TO ROLL THE CANOPY AND REMOVE IT FROM THE CANOPY FRAME. REFER TO CANOPY FRAME INSTRUCTIONS FOR FURTHER INFORMATION ON ADJUSTABILITY. REMOVE THE CARRIAGE BOLTS AND NYLOCK NUTS AND RETAIN THEM (FIGURE 1.1). REMOVE THE END HOOP AND REGULAR HOOPS FROM THE ADJUSTING RAILS (FIGURE 1.2).

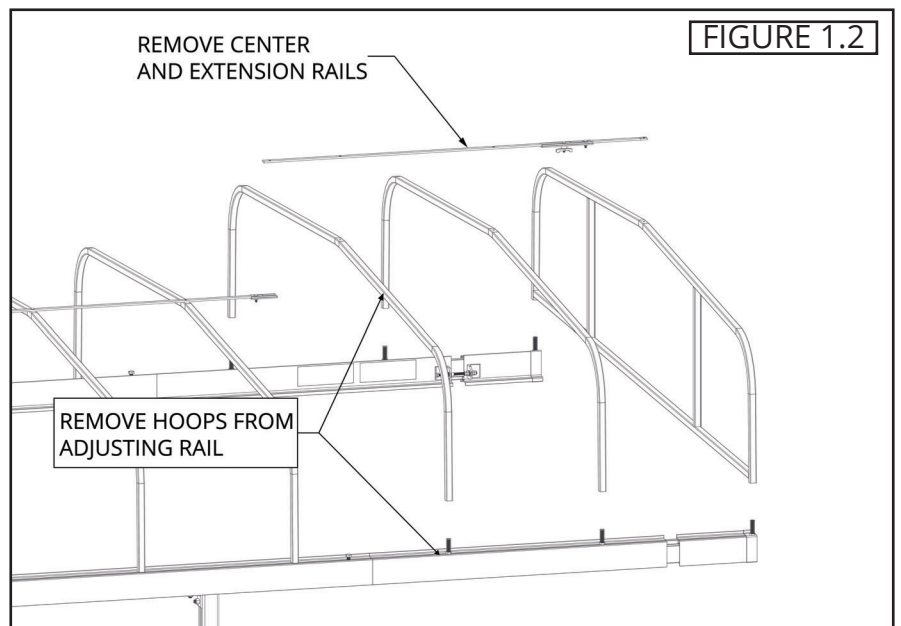
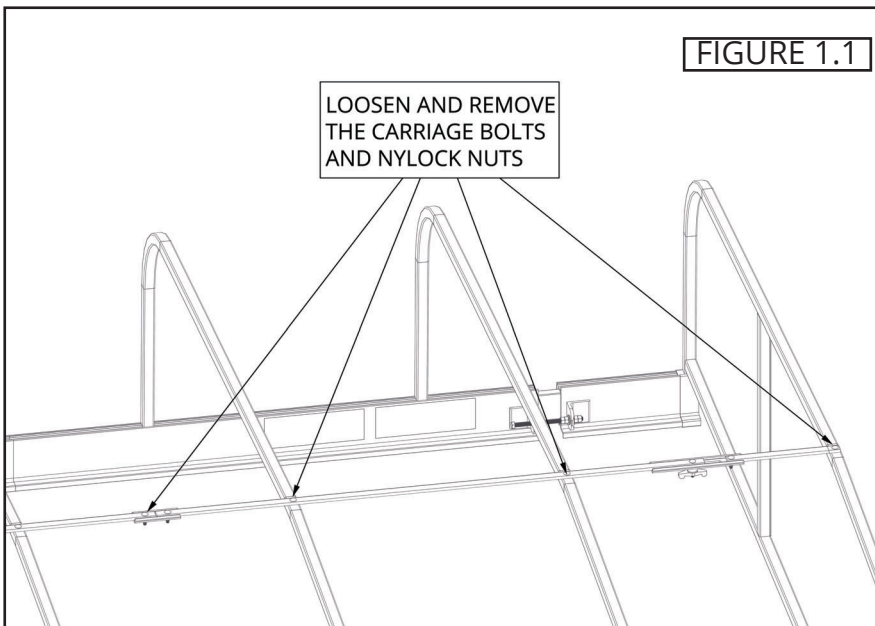

LOOSEN THE SET BOLT (**BUT DO NOT REMOVE**) AND REMOVE THE CANOPY ADJUSTING MAIN RAILS FROM THE OTHER RAILS (FIGURE 1.3). INSERT THE 48" MAIN RAILS FROM THE KIT INTO THE PLACES WHERE THE ADJUSTING MAIN RAILS PREVIOUSLY WERE AND INSTALL THE VINYL TUBES ONTO THE STUDS (FIGURE 1.4).

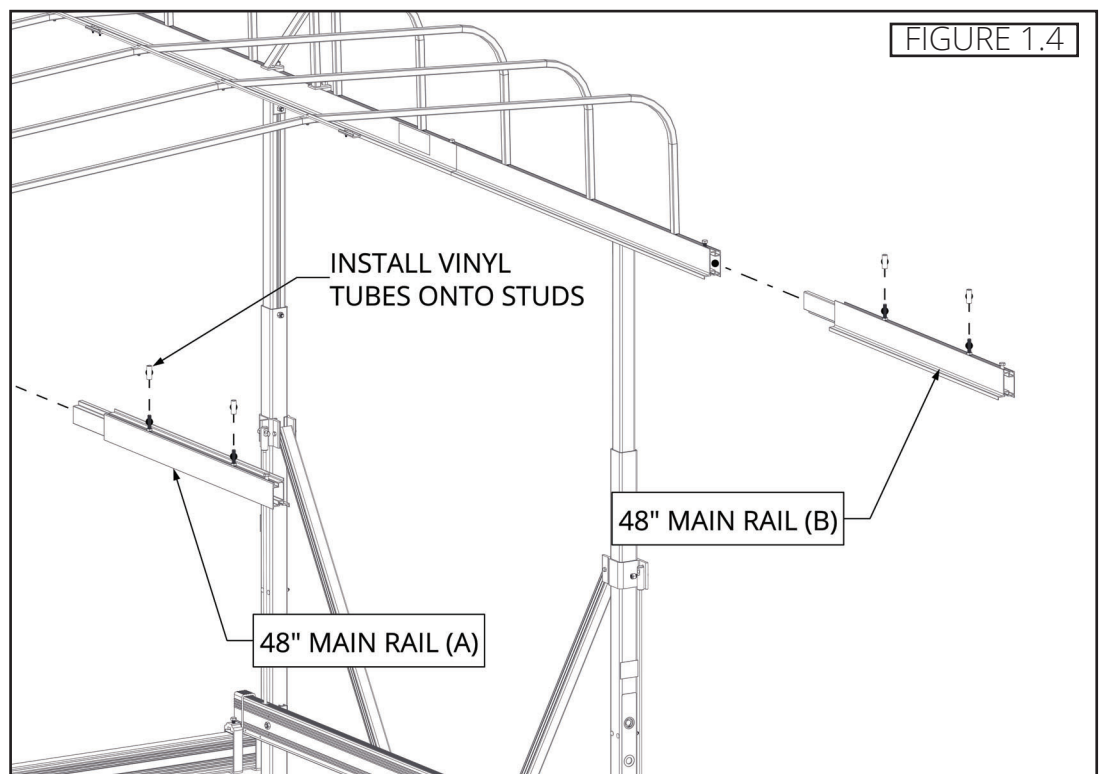
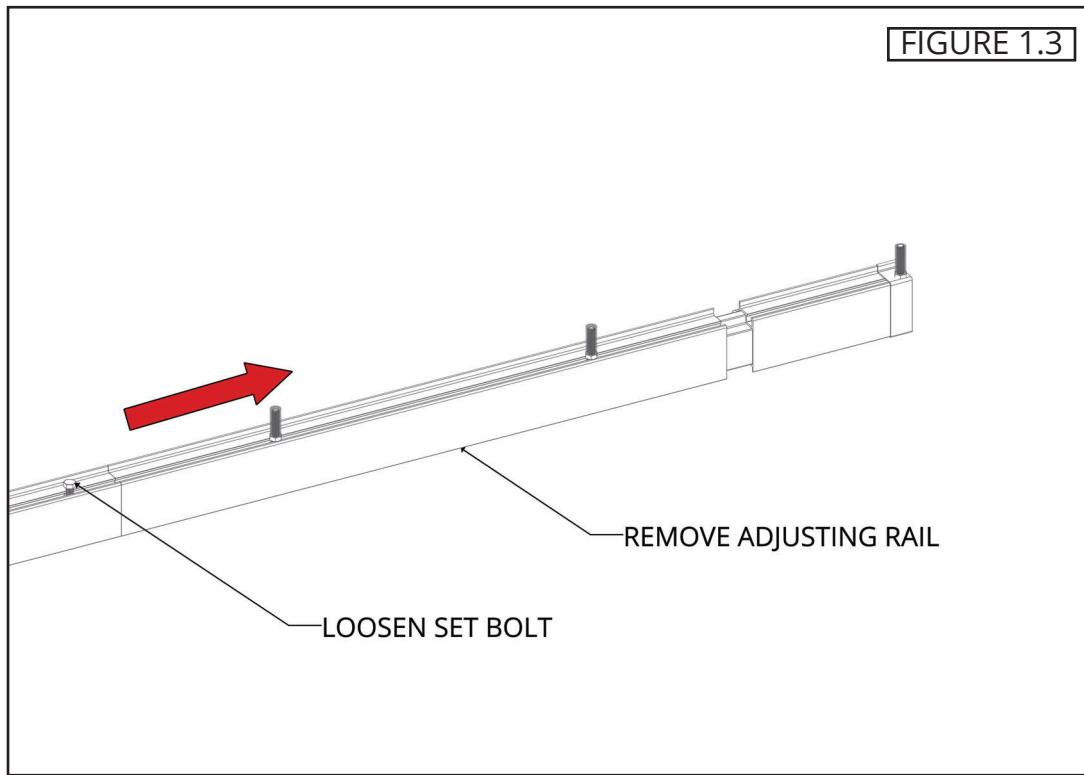

TORQUE THE SET BOLTS IN THE MAIN RAIL/SPLICE RAIL TO 25 FT-LB (FIGURE 1.5). INSTALL A CANOPY HOOP (NOT INCLUDED, MUST BE PURCHASED SEPARATELY, BASED UPON EXISTING CANOPY SIZE) ONTO BOTH SETS OF STUDS INSTALLED IN THE 48" MAIN RAILS (FIGURE 1.6).

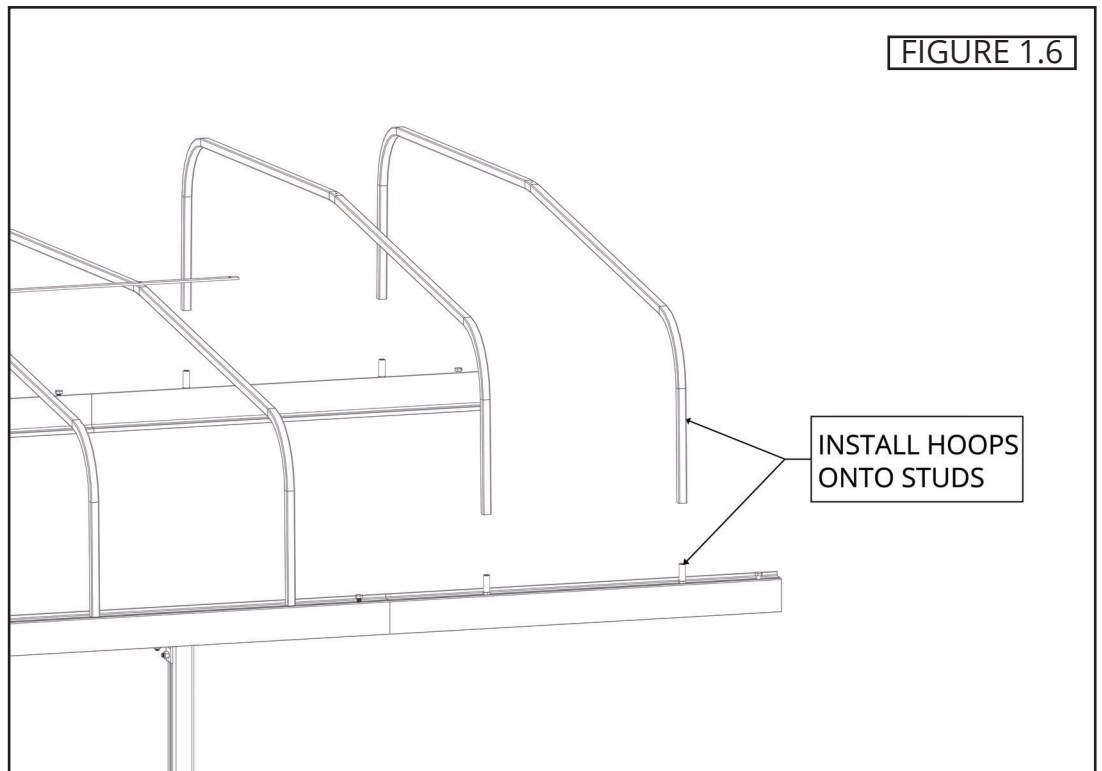
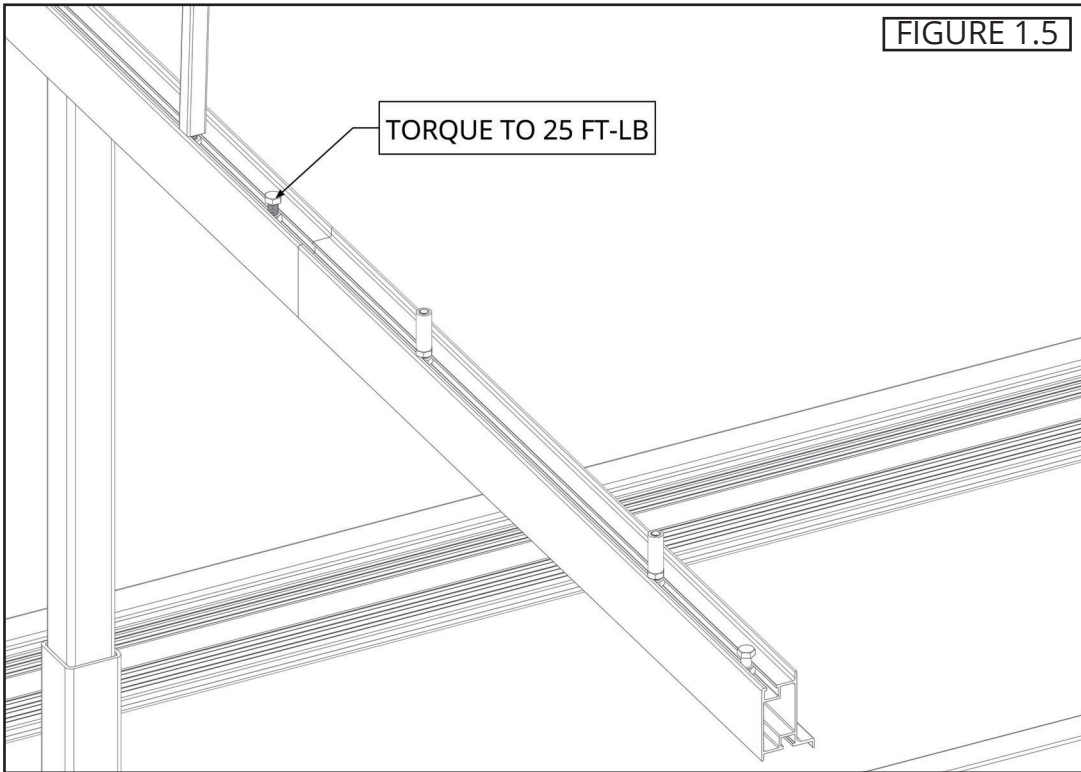

RE-INSTALL THE ADJUSTING MAIN RAILS INTO THE 48" MAIN RAILS (FIGURE 1.7). RE-INSTALL THE PREVIOUSLY REMOVED CANOPY HOOPS ONTO THE STUDS INSTALLED IN THE ADJUSTING MAIN RAILS. TORQUE THE SET BOLTS TO 25 FT-LB (FIGURE 1.8).

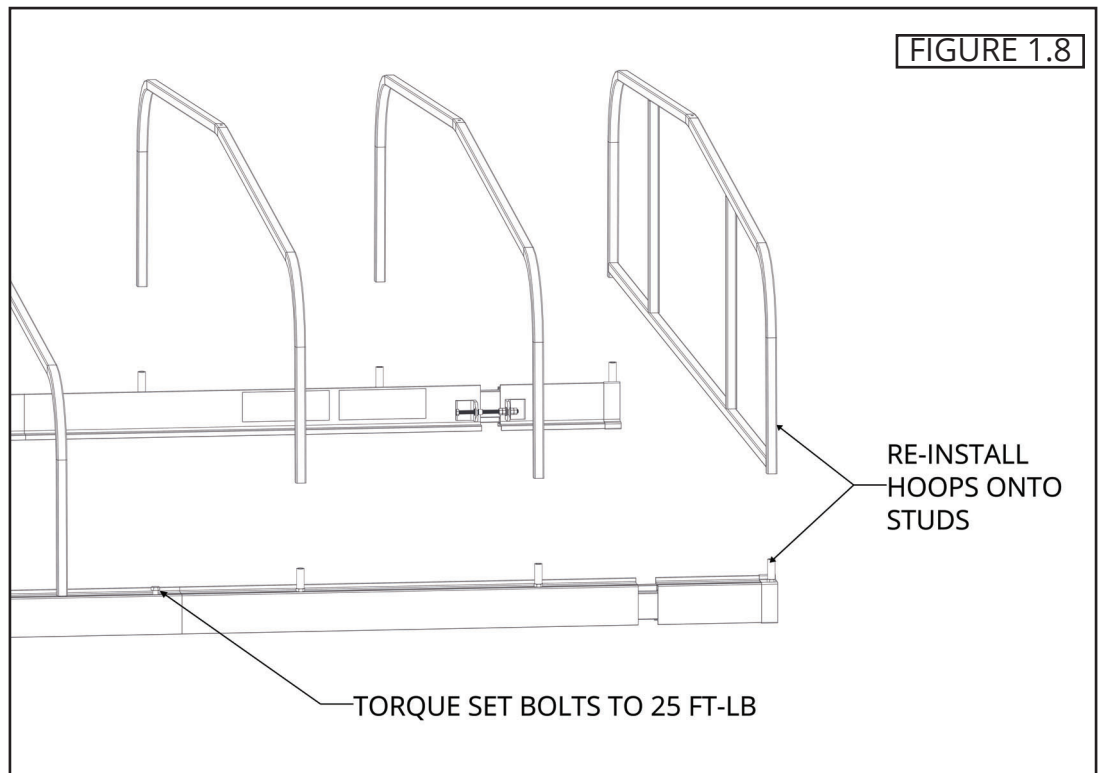
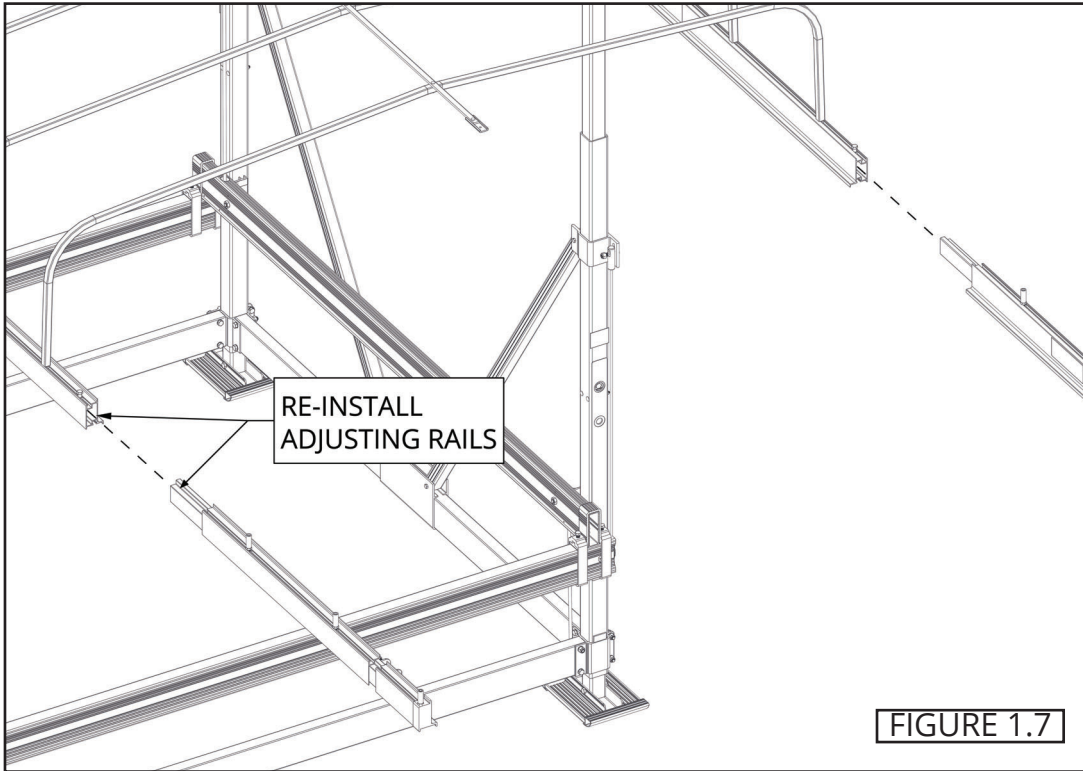

ATTACH THE INCLUDED 48" CENTER RAIL TO THE EXISTING CENTER RAIL USING (2) 1/4" X 1" CARRIAGE BOLTS, (2) 1/4" NYLOCK NUTS, AND THE SUPPLIED CENTER RAIL SPLICE. ATTACH THE 48" CENTER RAIL TO THE TOP OF THE CANOPY HOOPS USING (1) 1/4" X 1-1/2" CARRIAGE BOLT AND (1) 1/4" NYLOCK NUT PER HOOP. ATTACH THE 48" CENTER RAIL TO THE EXISTING RAIL SPLICE USING \*(1) 1/4" X 1" CARRIAGE BOLT AND \*(1) 1/4" NYLOCK NUT (FIGURE 1.9).

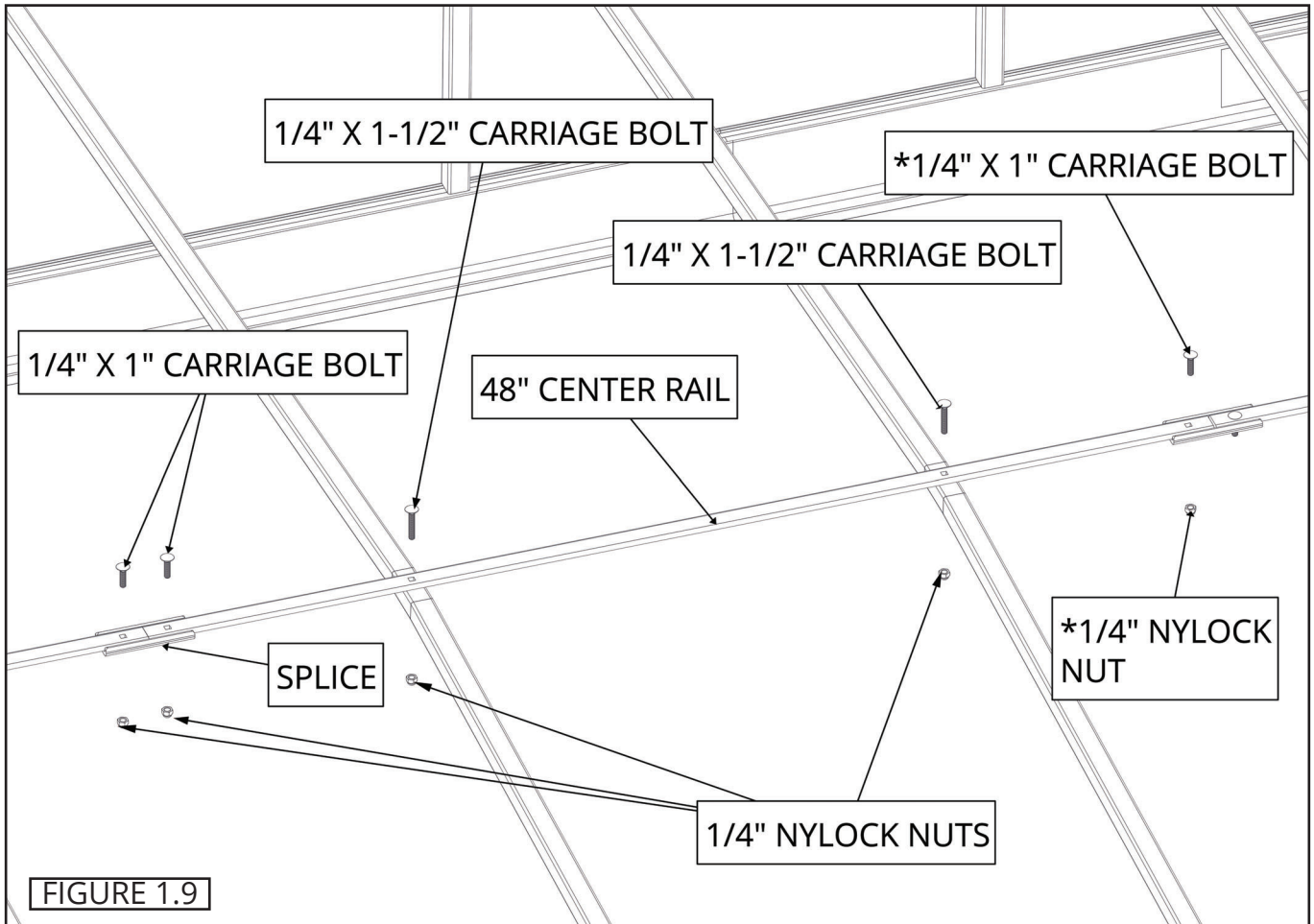

\*PREVIOUSLY REMOVED HARDWARE

RE-ATTACH THE REMAINING HOOPS TO THE EXISTING CENTER RAIL USING THE PREVIOUSLY REMOVED 1/4" X 1-1/2" CARRIAGE BOLTS AND 1/4" NYLOCK NUTS. RE-ATTACH THE END HOOP TO THE CENTER RAIL EXTENSION USING THE PREVIOUSLY REMOVED 1/4" X 1-3/4" CARRIAGE BOLT AND 1/4" NYLOCK NUT (FIGURE 1.10). INSTALL THE NEW CANOPY ONTO THE CANOPY FRAME. REFER TO THE CANOPY FRAME INSTRUCTIONS FOR INSTALLATION AND ADJUSTMENT.

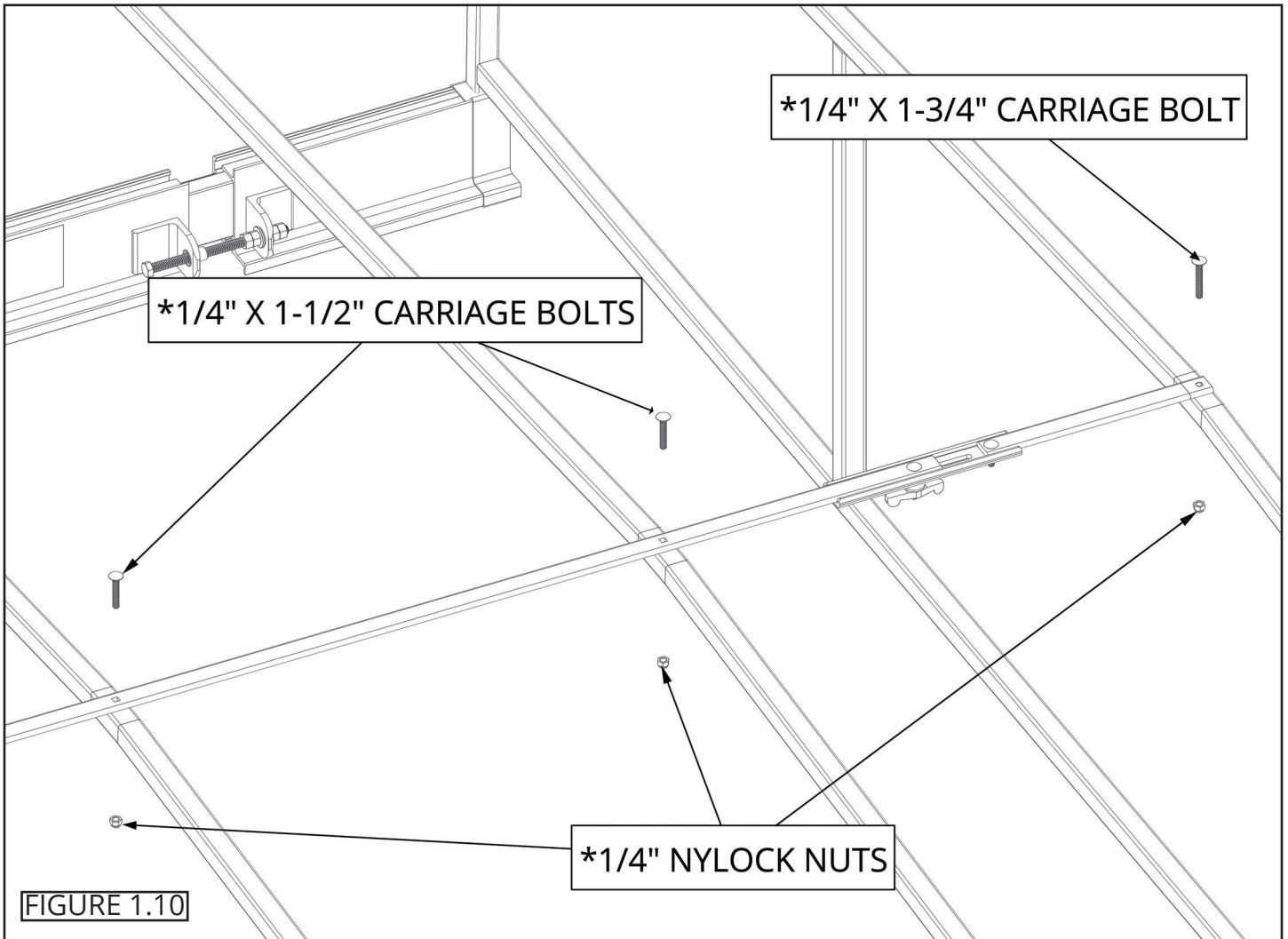

# **NOTES**

# **NOTES**

# **NOTES**



FLOE INTERNATIONAL, INC.  
48473 STATE HIGHWAY 65 • MCGREGOR, MN 55760  
[www.floeintl.com](http://www.floeintl.com)

*All material copyright © 2025 FLOE International, Inc.  
Specifications subject to change without notice.*