

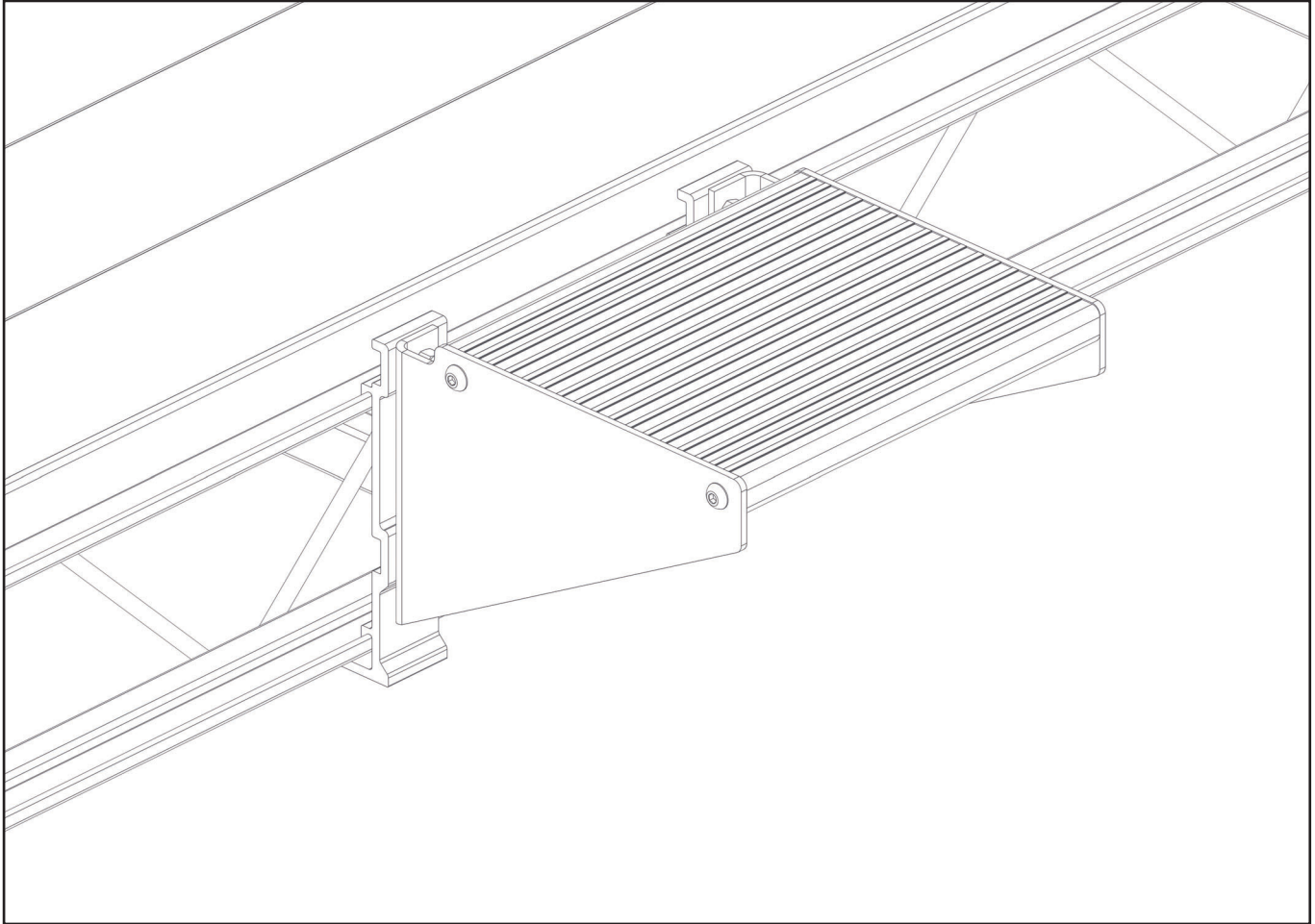

ASSEMBLY INSTRUCTIONS

FLOE QUICK ATTACH ROLL IN BOAT ACCESS STEP, 1' & 16" WIDE

P/N 510-42111-00



For more information, go to the owner support tab on the FLOE website

*DOCK NOT INCLUDED

TOOLS REQUIRED

- 7/32" SOCKET
 - *(2) 9/16" SOCKETS/WRENCHES
- (*NOTE: ONE OR TWO 9/16" WRENCHES/SOCKETS MAY BE REQUIRED, DEPENDING ON THE STYLE OF THE QUICK ATTACH ACCESSORY BRACKET)
- TORQUE WRENCH

BILL OF MATERIALS/EXPLODED VIEW

NUMBER	PART NUMBER	QTY	DESCRIPTION
	510-42100-00 OR 510-42101-00	1	STEP, 1' WIDE - GREY OR STEP, 1' WIDE - AG CHESTNUT
1	001-42100-00	1	FASTENERS, 1' DOCK STEP
1A	001-73815-00	4	BHCS, 3/8-16 X 1" SS
2	002-42101-00 OR 002-42100-00	1	PLANK, DOCK STEP 10" X 12" GREY OR PLANK, DOCK STEP 10" X 12" AG CHESTNUT
3	002-42102-00	1	BRACKET, QA DOCK STEP MOUNTING - SIDE A
4	002-42103-00	1	BRACKET, QA DOCK STEP MOUNTING - SIDE B
	510-42111-00		KIT, QA ROLL IN DOCK STEP ATT.
5	001-02573-01	1	FASTENERS, QUICK ATT.
5A	001-70105-00	6	HHCS, 3/8-16 X 1" 18-8 SS
5B	001-76071-00	4	NUT, NYLOCK 3/8-16 ALUM.
6	002-00276-00	2	BRACKET, QA ROLL-IN ACC. - 2"

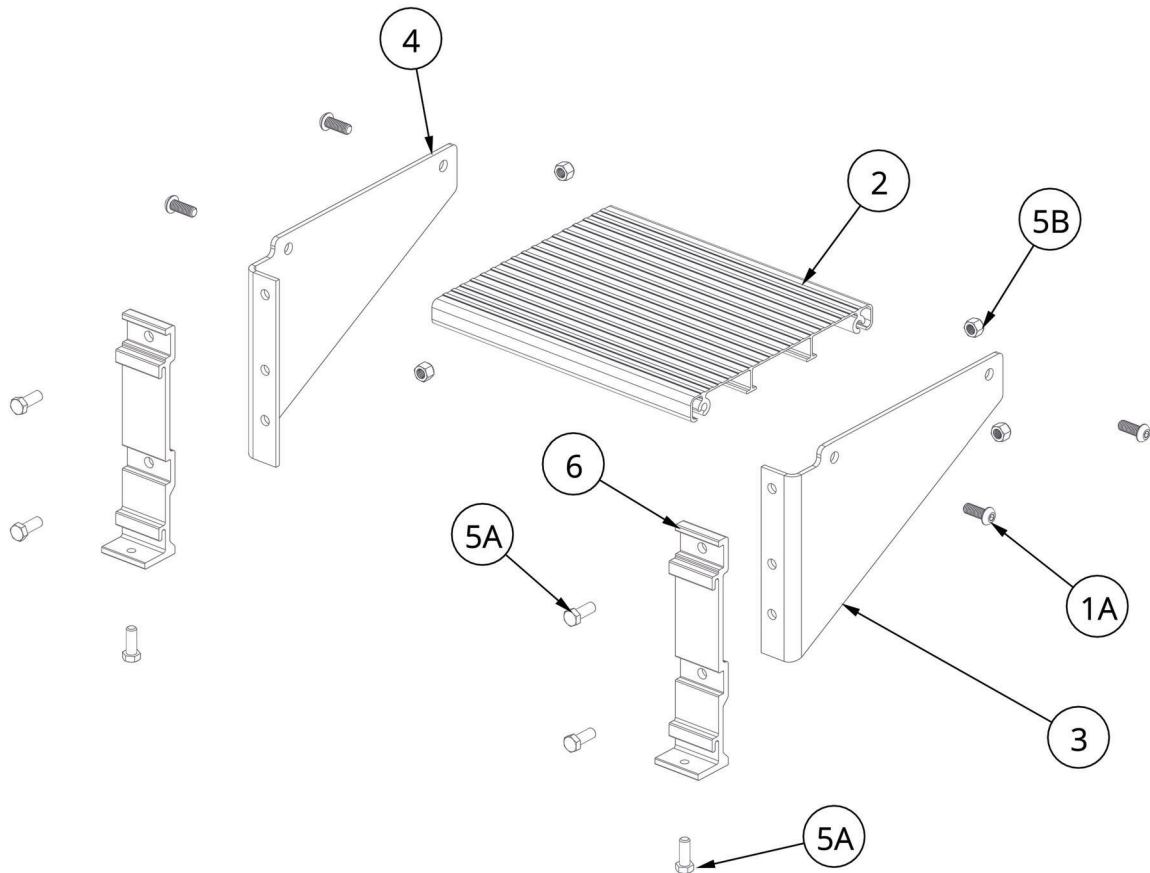

BILL OF MATERIALS/EXPLODED VIEW

NUMBER	PART NUMBER	QTY	DESCRIPTION
	510-42102-00 OR 510-42103-00	1	STEP, 16" WIDE - GREY OR STEP, 16" WIDE - AG CHESTNUT
1	001-42100-00	1	FASTENERS, DOCK STEP
1A	001-73815-00	4	BHCS, 3/8-16 X 1" SS
2	002-42105-00 OR 002-42104-00	1	PLANK, DOCK STEP 10" X 16" GREY OR PLANK, DOCK STEP 10" X 16" AG CHESTNUT
3	002-42102-00	1	BRACKET, QA DOCK STEP MOUNTING - SIDE A
4	002-42103-00	1	BRACKET, QA DOCK STEP MOUNTING - SIDE B
	510-42111-00		KIT, QA ROLL IN DOCK STEP ATT.
5	001-02573-01	1	FASTENERS, QUICK ATT.
5A	001-70105-00	6	HHCS, 3/8-16 X 1" 18-8 SS
5B	001-76071-00	4	NUT, NYLOCK 3/8-16 ALUM.
6	002-00276-00	2	BRACKET, QA ROLL-IN ACC. - 2"

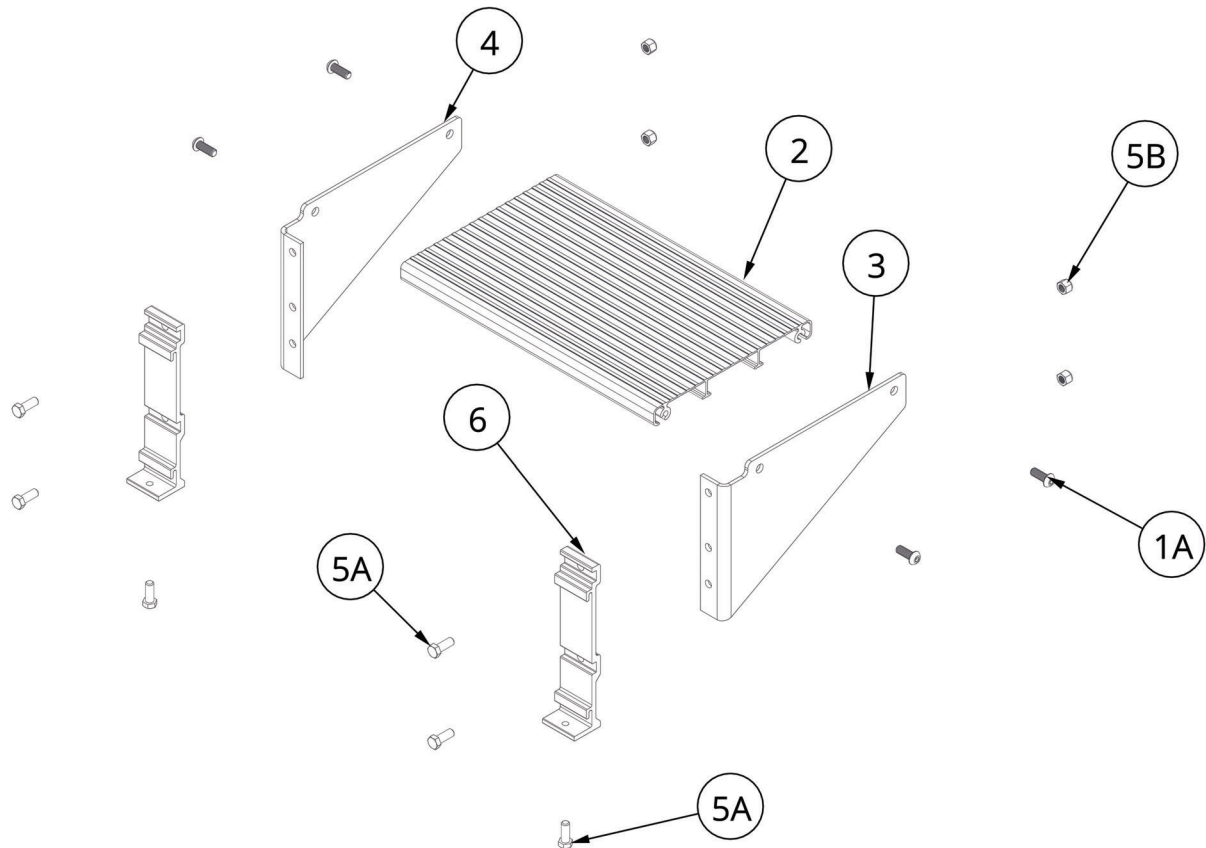

ASSEMBLY (1' WIDE SHOWN)

ATTACH THE PLANK TO THE MOUNTING BRACKETS USING (4) 3/8" X 1" BUTTON HEAD BOLTS (FIGURE 1.1). TIGHTEN TO REMOVE PLAY IN THE BOLTS AND ALLOW FOR SLIGHT MOVEMENT WHEN INSTALLING ONTO THE DOCK SIDE WITH THE BRACKETS. THESE WILL BE TIGHTENED FULLY IN THE LAST STEP (FIGURE 1.2).

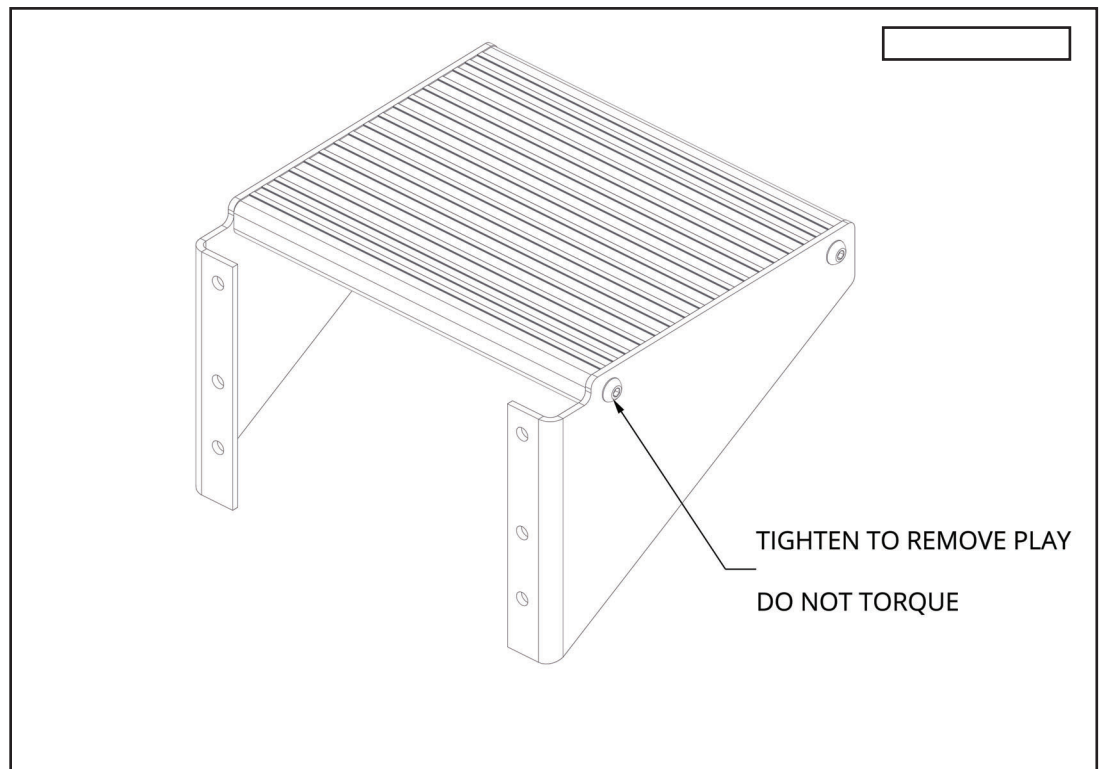
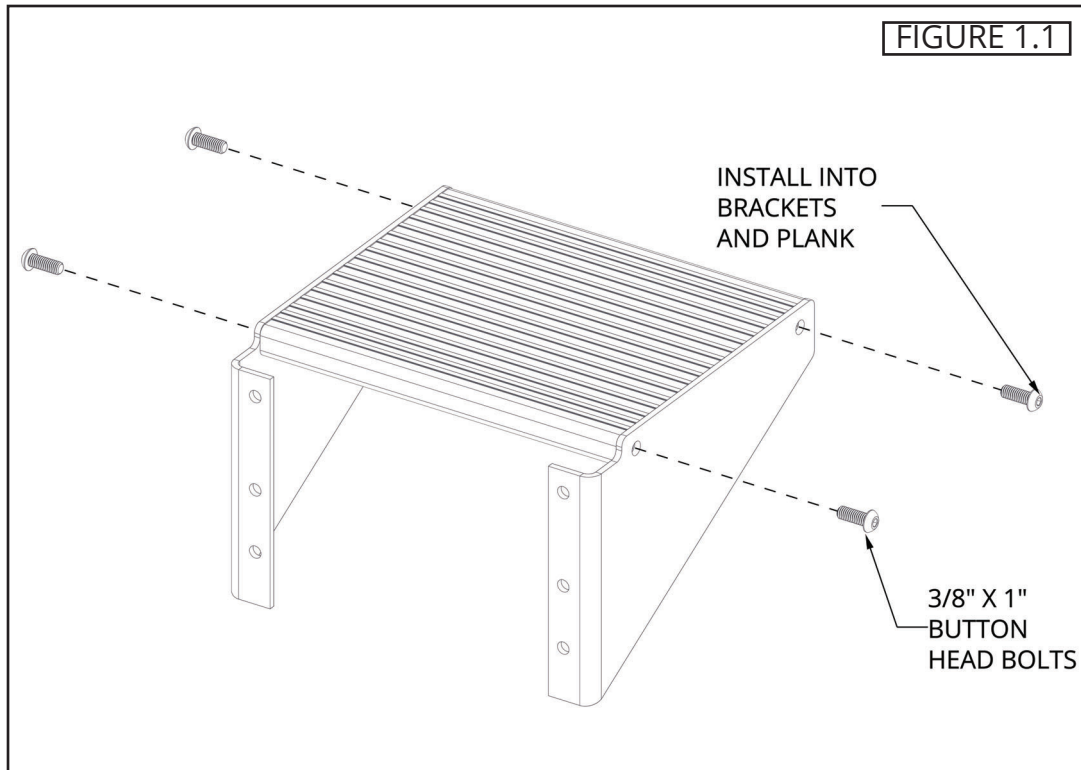

ATTACH THE QUICK ATTACH BRACKETS TO THE MOUNTING BRACKETS USING (2) 3/8" X 1" BOLTS AND (2) 3/8" NYLOCK NUTS PER BRACKET (FIGURE 1.3). TORQUE TO 35 FT-LB (FIGURE 1.4).

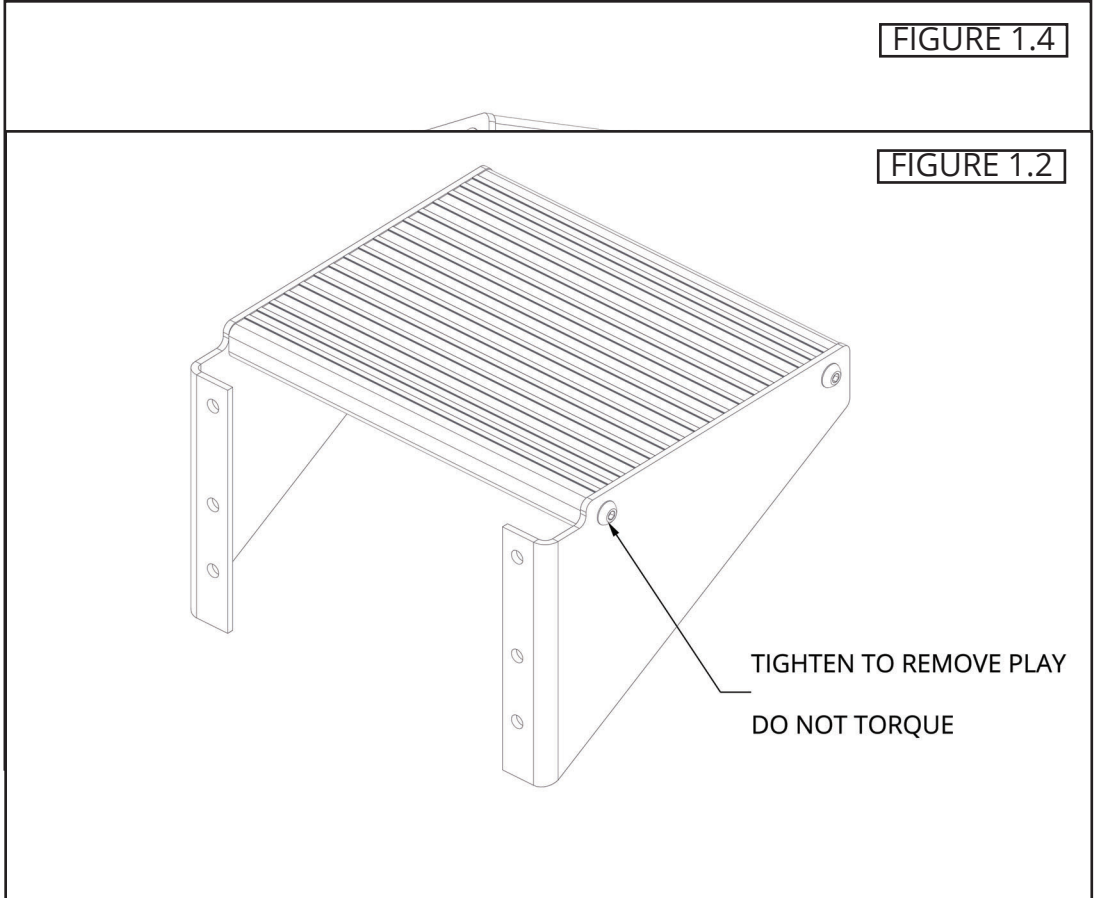
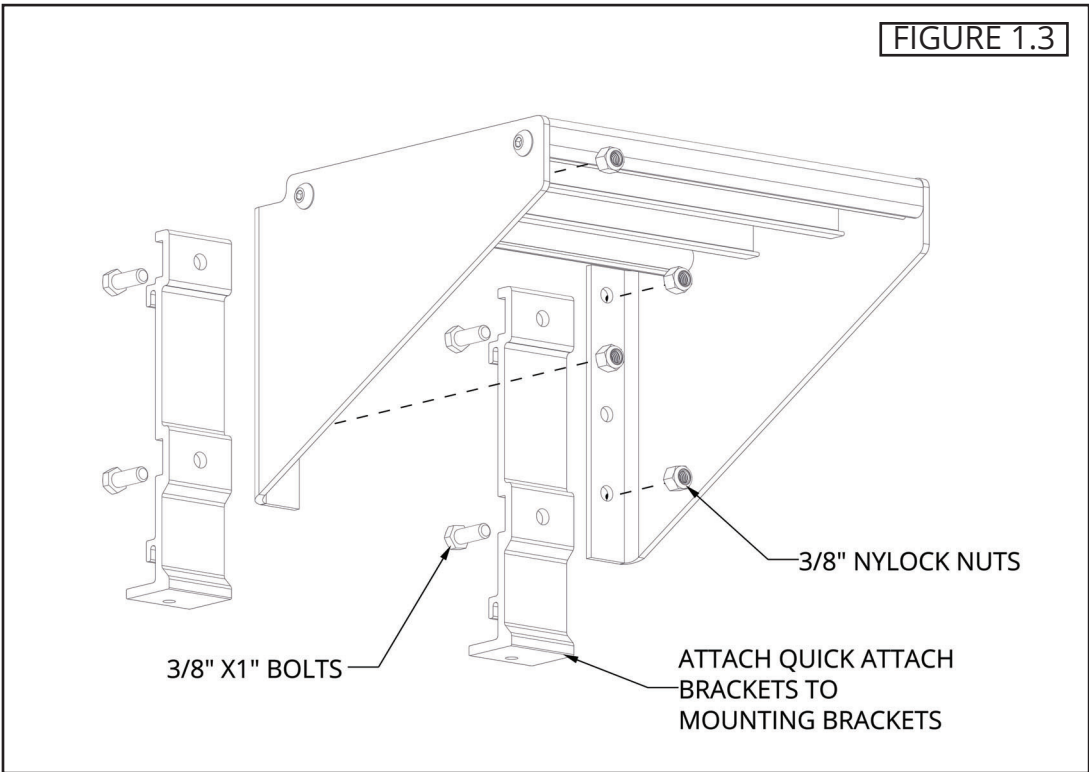

INSTALLATION (1' WIDE SHOWN)

PLACE THE DOCK STEP ASSEMBLY IN THE DESIRED LOCATION ON THE SIDE OF THE DOCK (FIGURE 2.1). ATTACH THE DOCK STEP BY INSTALLING A 3/8" X 1" BOLT INTO EACH BRACKET (FIGURE 2.2). TORQUE TO 6 FT-LB MAXIMUM (FIGURE 2.3).

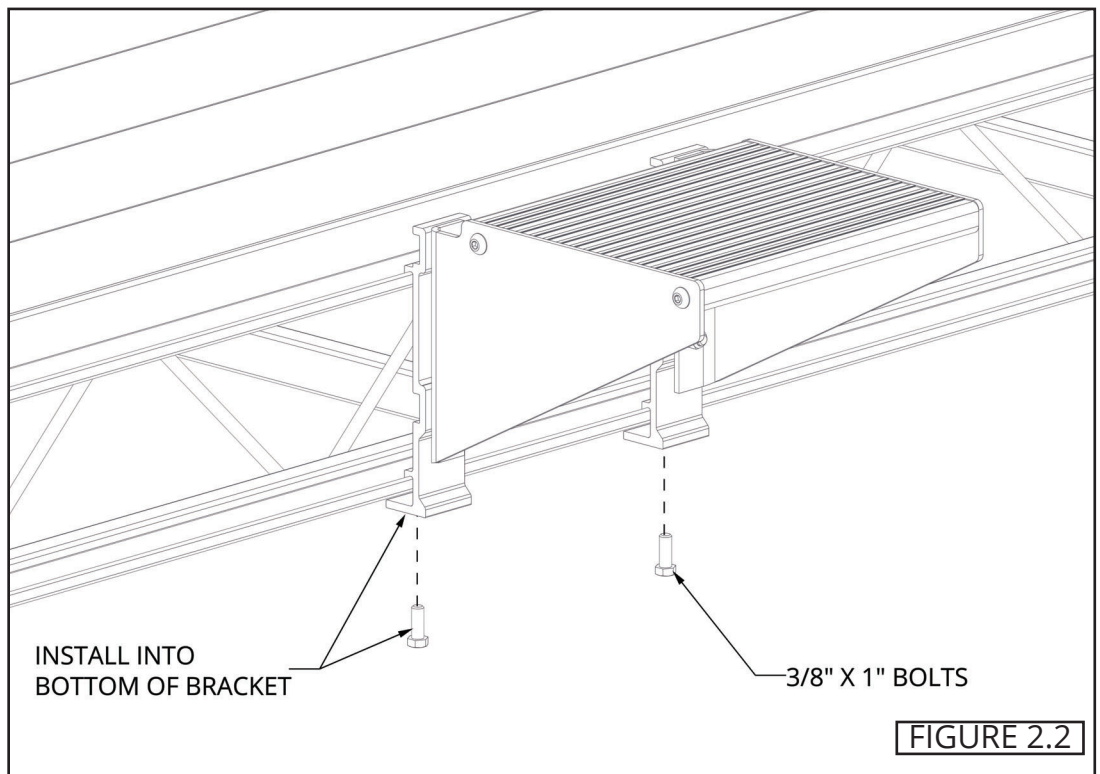
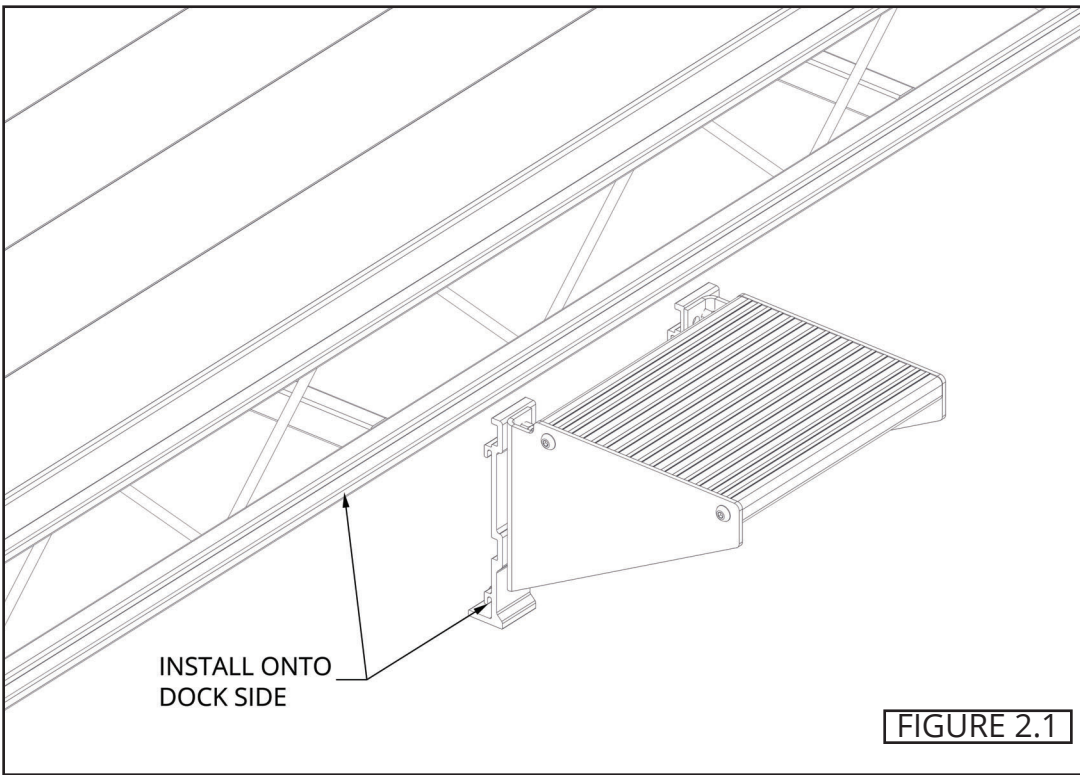

TORQUE TO 6 FT-LB MAXIMUM (FIGURE 2.3). TORQUE TO 10 FT-LB (FIGURE 2.4).

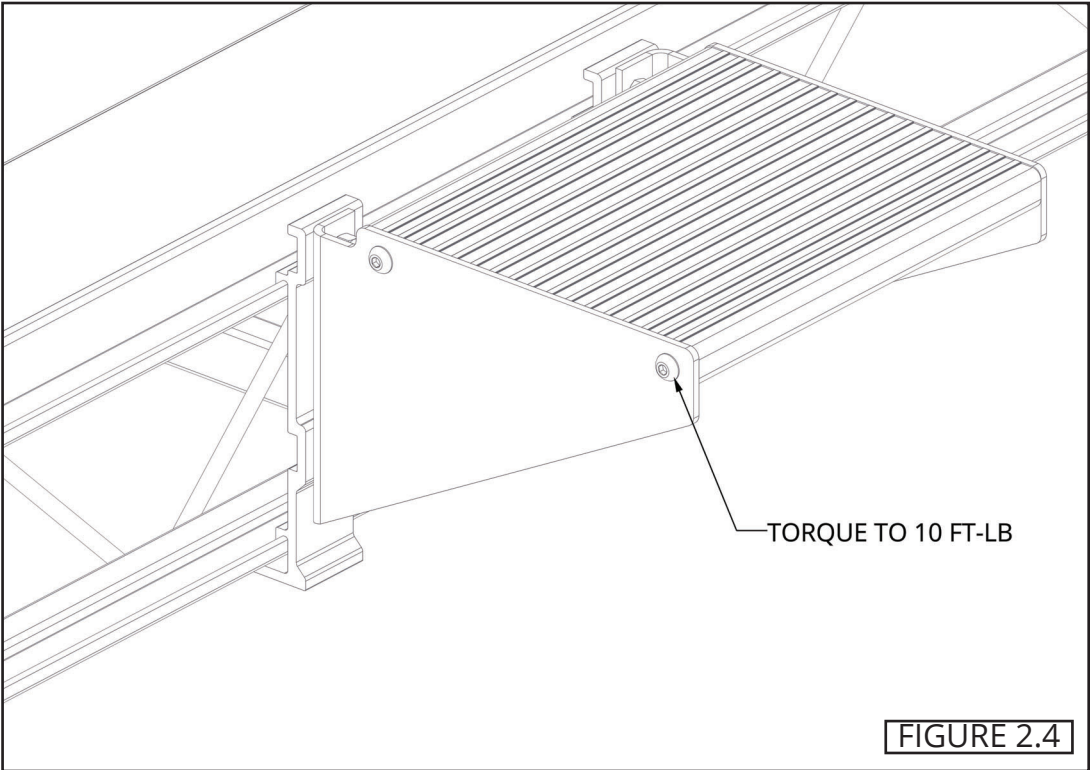
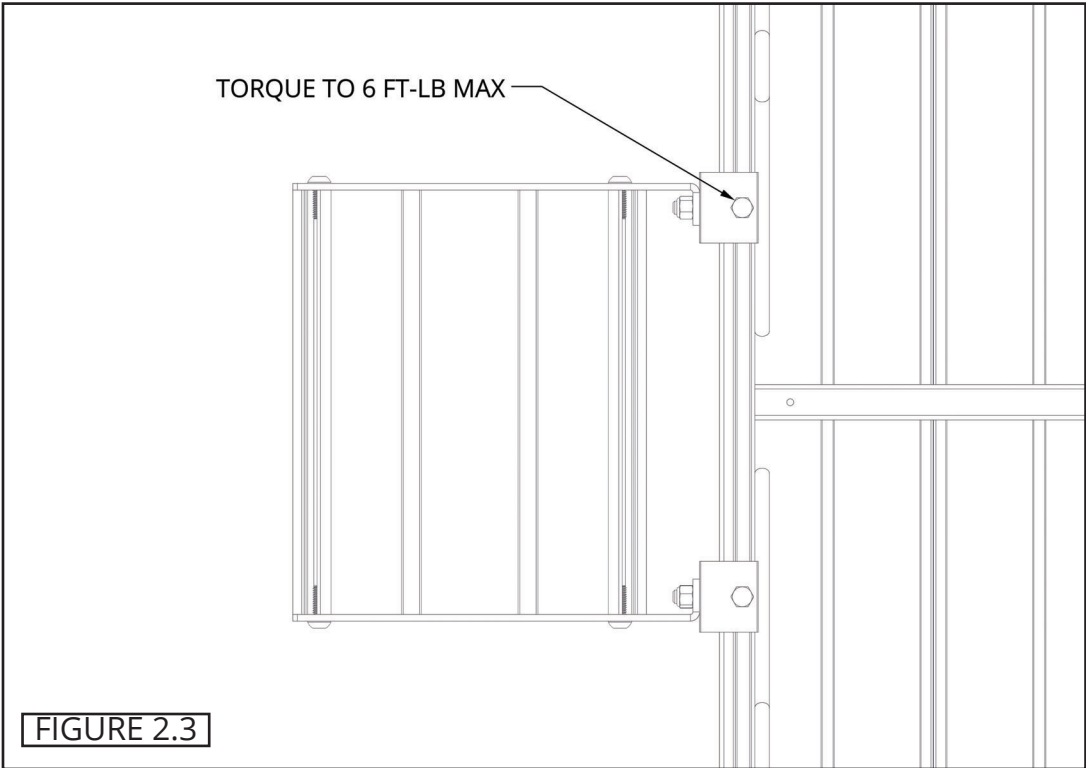



FLOE INTERNATIONAL, INC.
48473 STATE HIGHWAY 65 • MCGREGOR, MN 55760
www.floeintl.com

*All material copyright © 2025 FLOE International, Inc.
Specifications subject to change without notice.*