

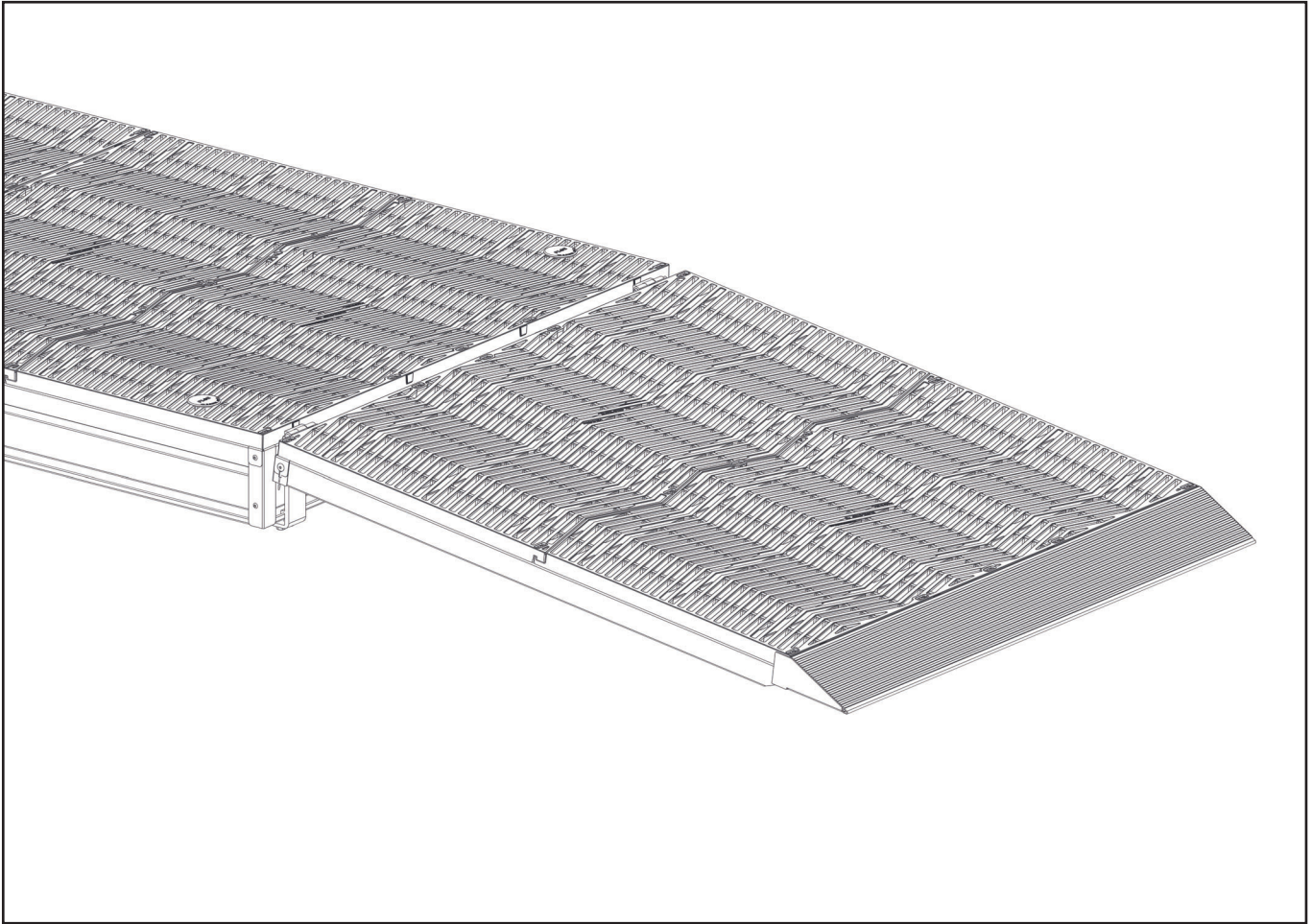

# ASSEMBLY INSTRUCTIONS

## FLOE VERSATILE HEAVY DUTY DOCK SHORE END TRANSITION MOUNT KIT

P/N 510-09410-00



For more information, go to the owner support tab on the FLOE website

\*DOCK & SHORE END TRANSITION NOT INCLUDED

### TOOLS REQUIRED

- 9/16" SOCKET/WRENCH
- TORQUE WRENCH

# **BILL OF MATERIALS/EXPLODED VIEW**

NUMBER	PART NUMBER	QTY	DESCRIPTION
	<b>510-09410-00</b>	<b>1</b>	<b>KIT, SE TRANSITION QA FM MNT</b>
1	001-02576-01	2	FASTENERS, QUICK ATT.
1A	001-70105-00	2 (4 TOTAL)	HHCS, 3/8-16 X 1" 18-8 SS
2	110-09410-00	2	WELD'T, QA FM SE TRANS PIVOT BRKT

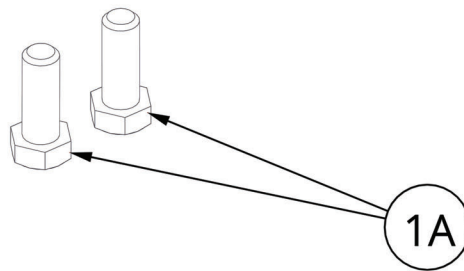
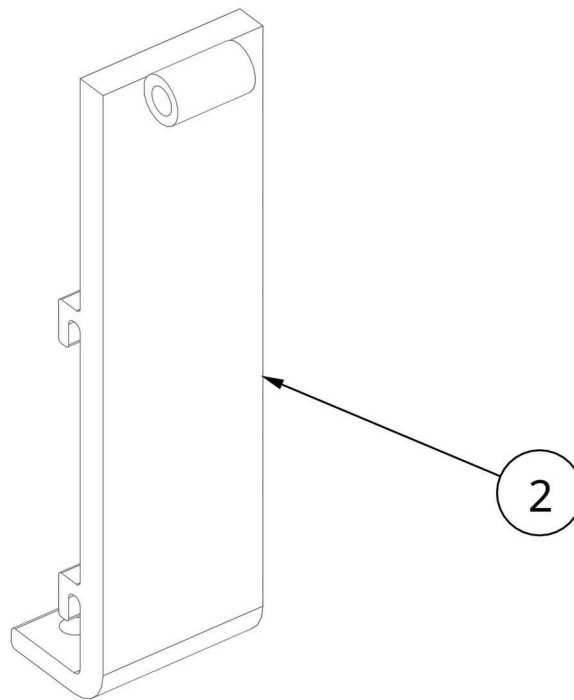

# ASSEMBLY

REMOVE THE PINS OUT OF THE HINGES ON THE TRANSITION (FIGURE 1.1). ALIGN THE HINGES ON THE TRANSITION WITH THE HINGE ON THE TRANSITION MOUNT (FIGURE 1.2).

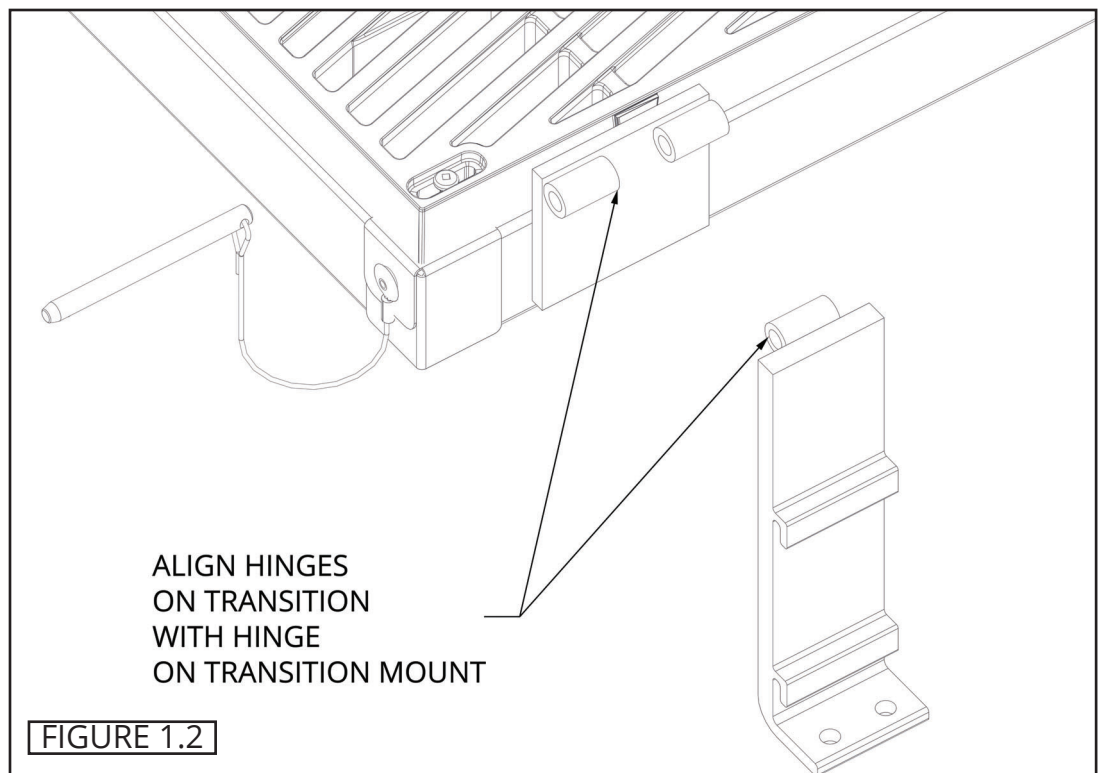
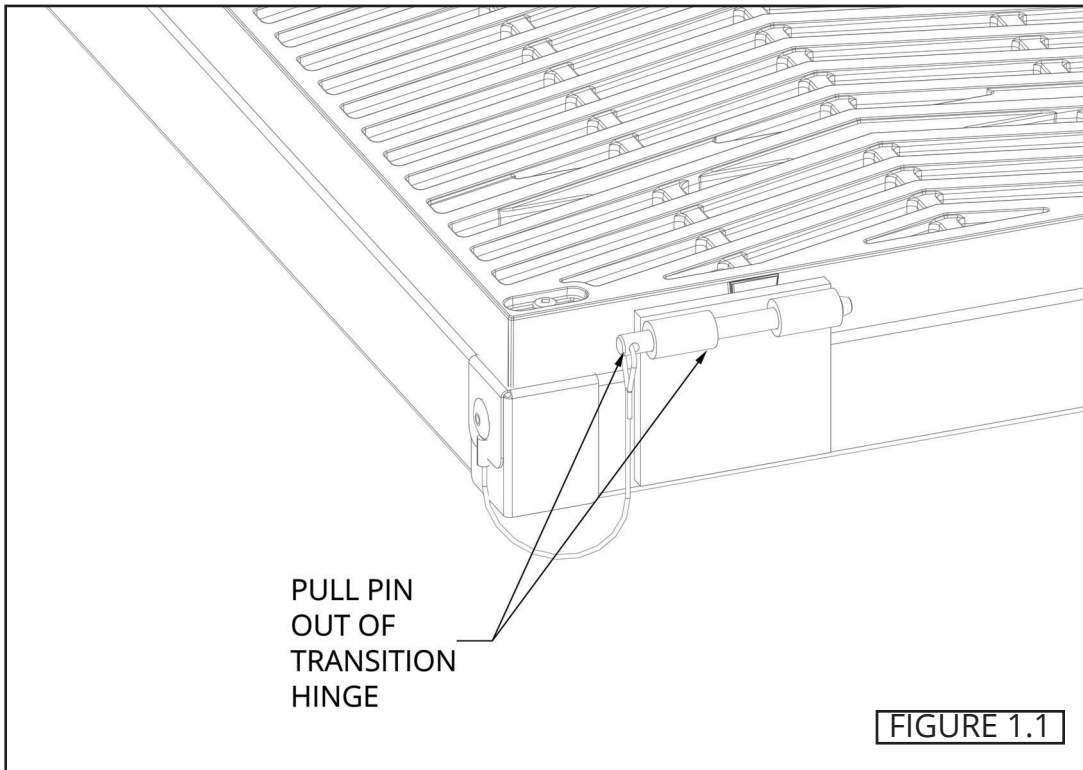

RE-INSERT THE PINS ON THE TRANSITION INTO THE HINGES ON THE TRANSITION AND HINGES ON THE MOUNT (FIGURE 1.3). POSITION THE TRANSITION WITH MOUNTS ONTO THE END OF THE DOCK WHILE ENSURING THAT THE SIDE OF THE TRANSITION IS FLUSH WITH THE SIDE OF THE DOCK (FIGURE 1.4 & 1.5).

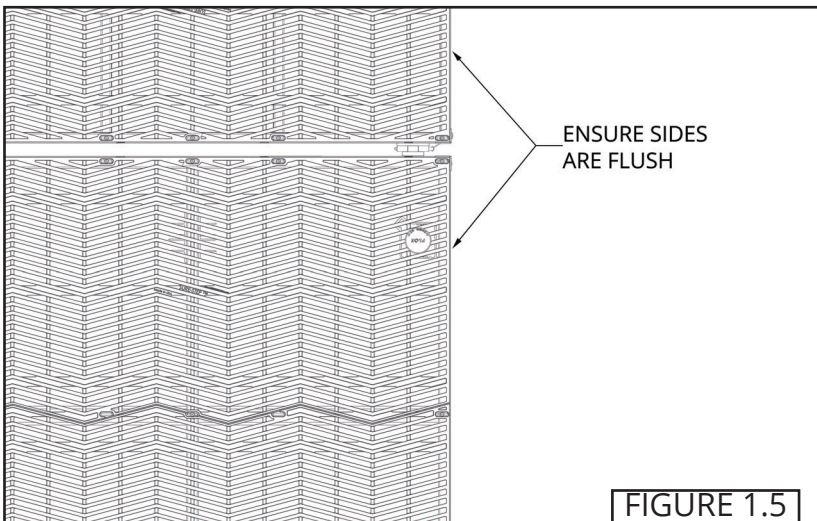
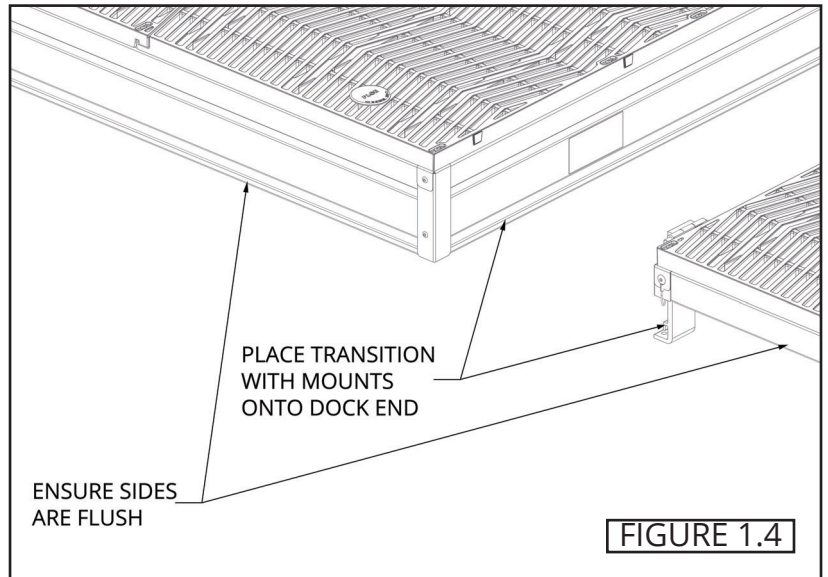
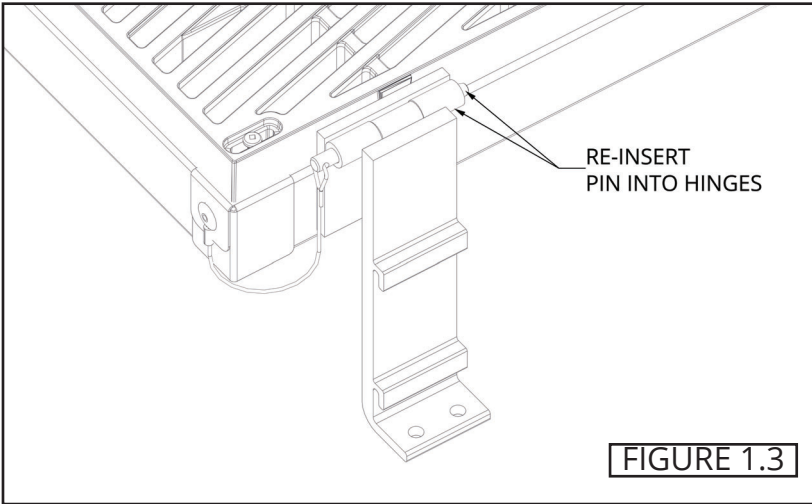

INSERT (2) 3/8" X 1" BOLTS INTO BOTTOM OF EACH TRANSITION MOUNT (FIGURE 1.6). TORQUE TO 6 FT-LB MAXIMUM (FIGURE 1.7).

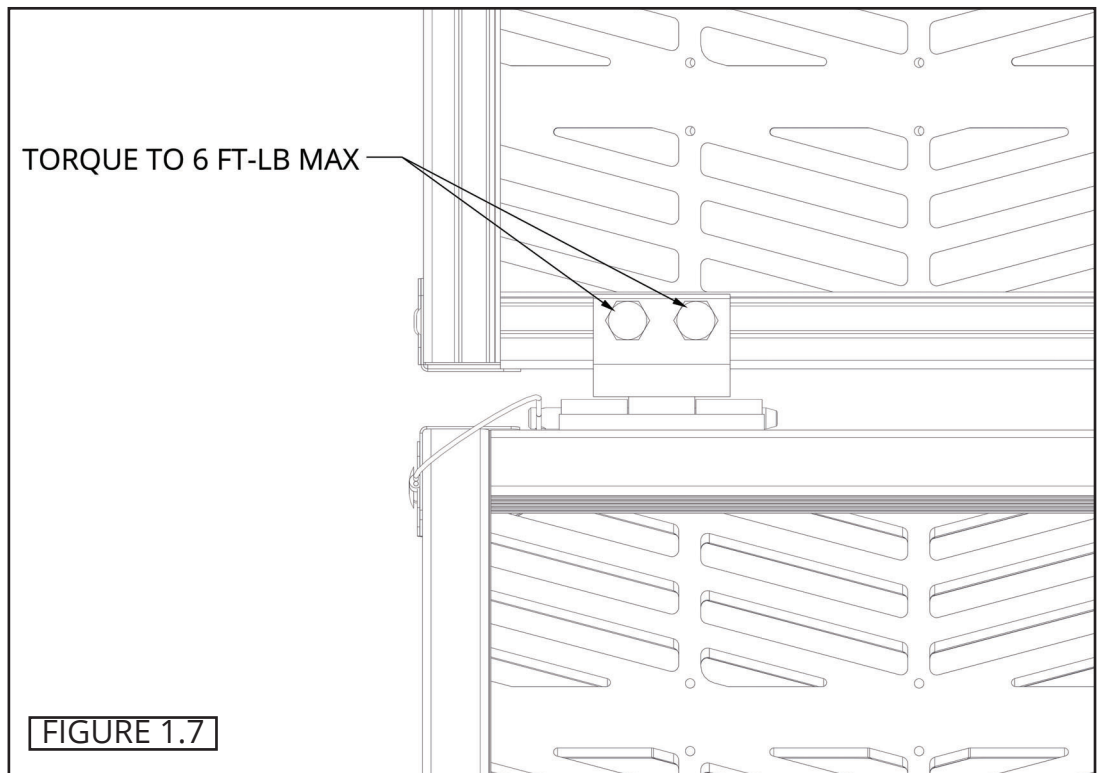
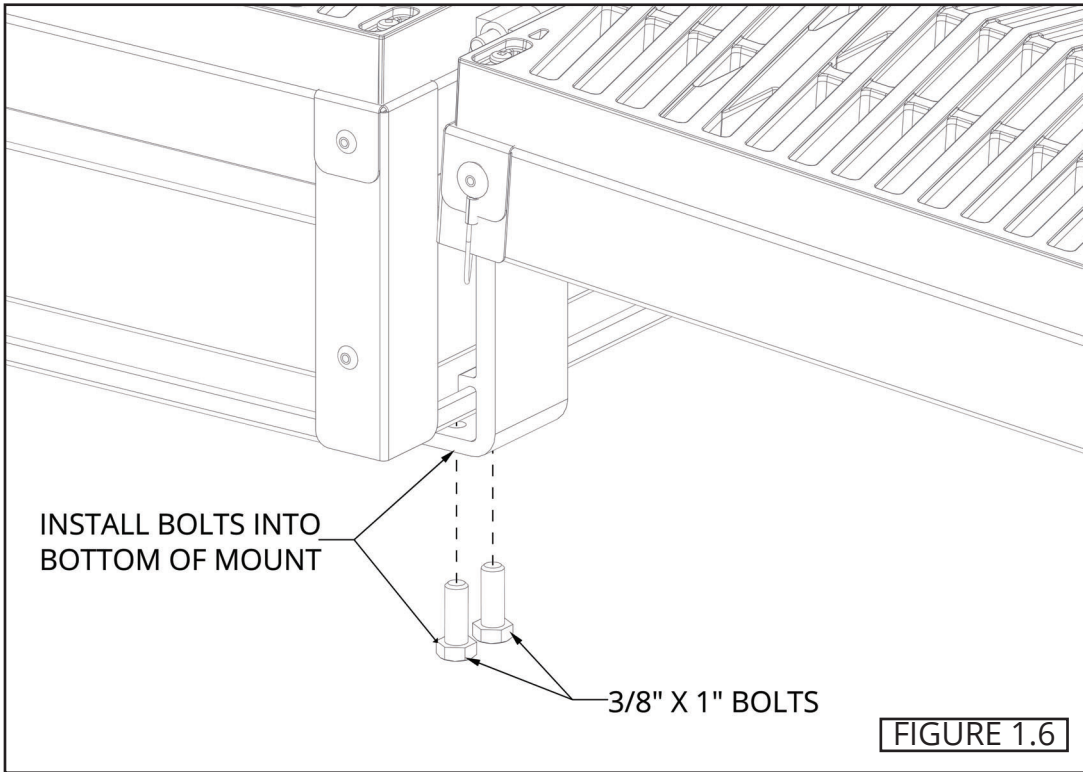

**NOTES**

# **NOTES**



FLOE INTERNATIONAL, INC.  
48473 STATE HIGHWAY 65 • MCGREGOR, MN 55760  
[www.floeintl.com](http://www.floeintl.com)

*All material copyright © 2025 FLOE International, Inc.  
Specifications subject to change without notice.*