

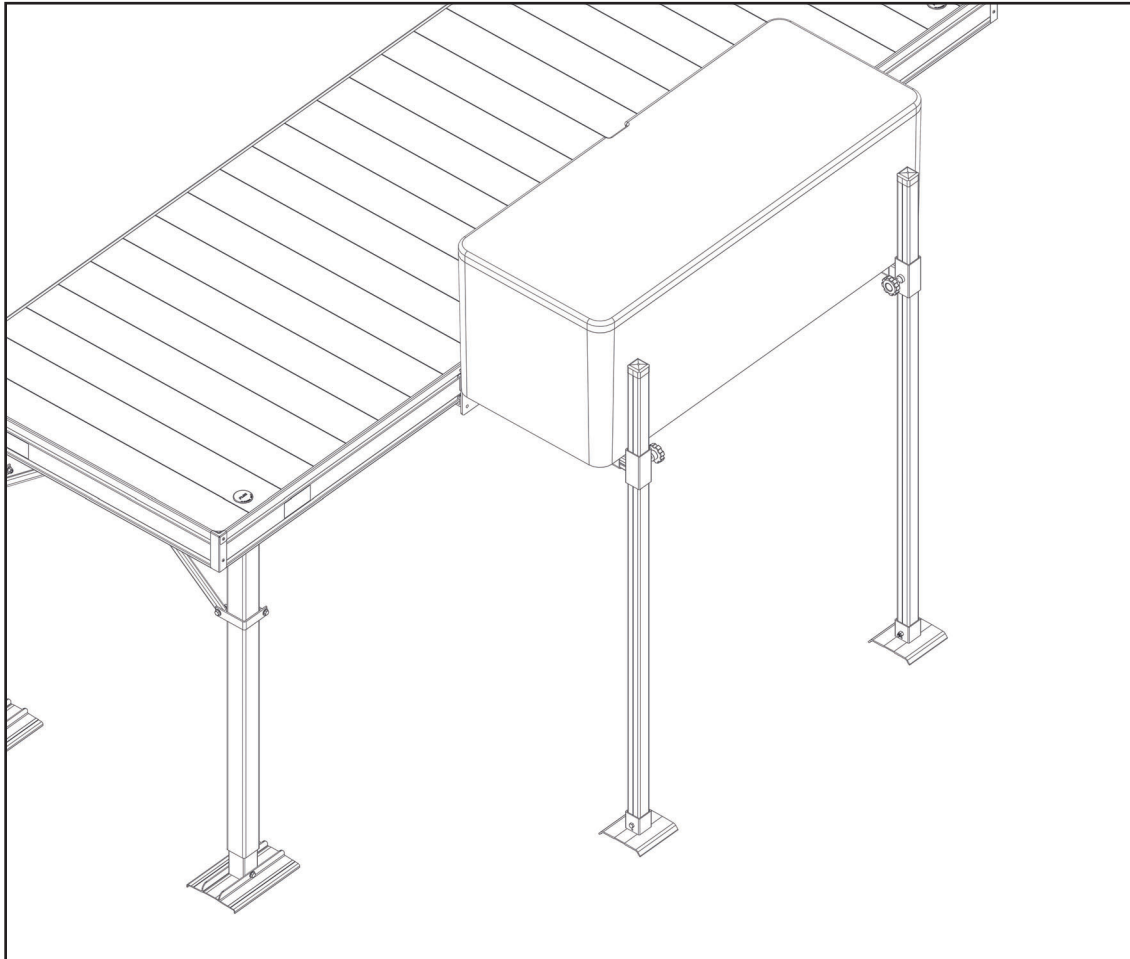

# ASSEMBLY INSTRUCTIONS

## FLOE QUICK ATTACH SECTIONAL DOCK DOCK BOX SUPPORT FRAME ATTACHMENT KIT

P/N 510-02665-00



For more information, go to the owner support tab on the FLOE website

\*DOCK, DOCK LEGS, DOCK BOX SUPPORT FRAME, AND DOCK BOX NOT INCLUDED

### TOOLS REQUIRED

- 9/16" SOCKET/WRENCH (NOTE: (2) 9/16" SOCKETS/WRENCHES MAY BE REQUIRED, DEPENDING ON THE STYLE OF QUICK ATTACH ACCESSORY BRACKET)
  - 3/4" WRENCH/SOCKET
  - TORQUE WRENCH
  - TAPE MEASURE
- DOCK BOX SUPPORT FRAME INSTRUCTIONS

# BILL OF MATERIALS/EXPLODED VIEW

NUMBER	PART NUMBER	QTY	DESCRIPTION
	<b>510-02665-00</b>	<b>1</b>	<b>KIT, QA SCTN'L. DOCK BOX ATT.</b>
1	001-02573-01	1	FASTENERS, QUICK ATT.
1A	001-70105-00	6 (12 TOTAL)	HHCS, 3/8-16 X 1" 18-8 SS
1B	001-76071-00	4 (8 TOTAL)	NUT, NYLOCK 3/8-16 ALUM.
2	002-00150-01	2	BRACKET, QA SCTN'L ACCY. - 2"

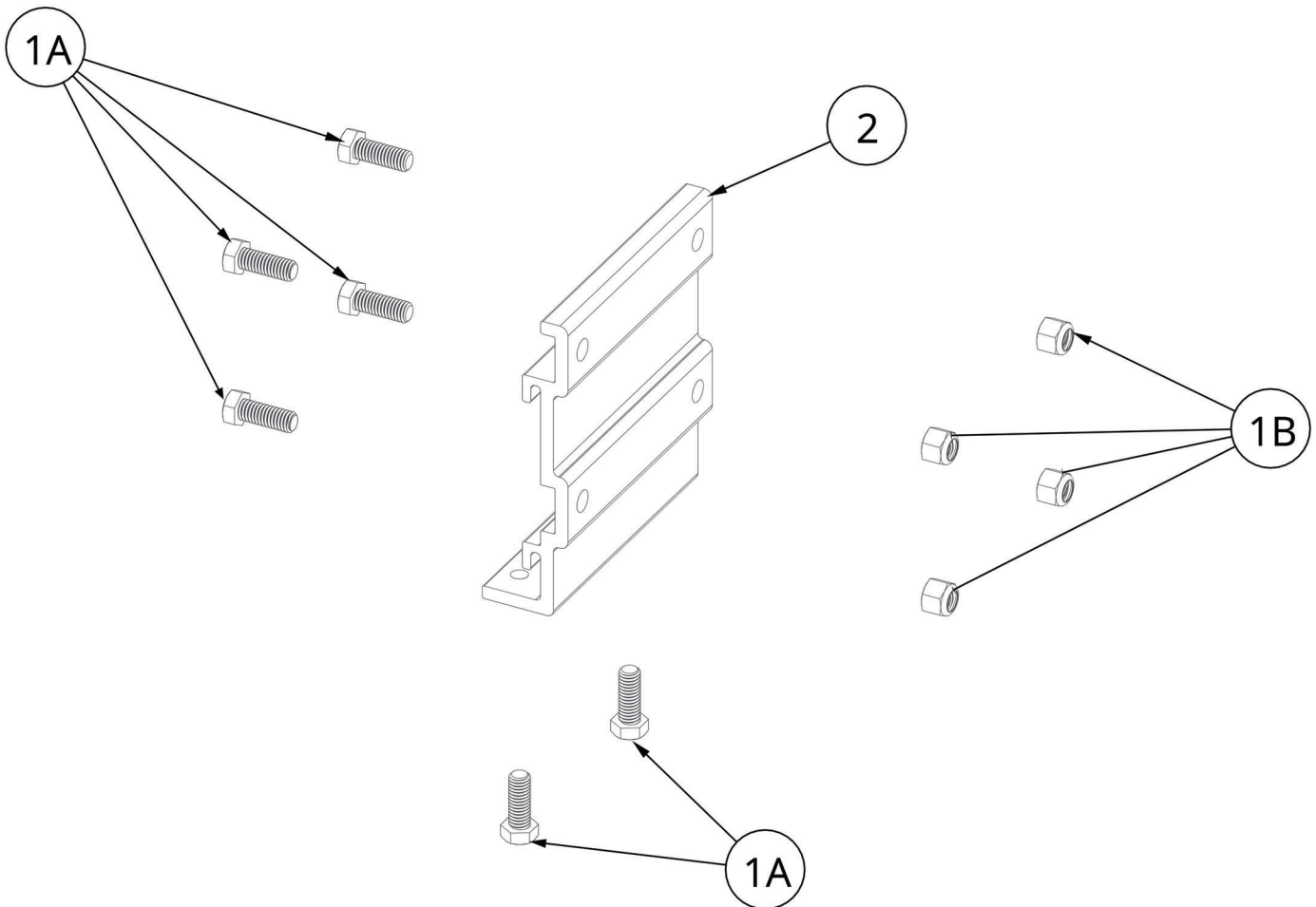

# INSTALLATION

REFER TO THE DOCK BOX SUPPORT FRAME INSTRUCTIONS TO ASSEMBLE THE FRAME. DETERMINE THE DESIRED LOCATION OF THE DOCK BOX. ATTACH THE SUPPORT ARMS TO THE QUICK ATTACH BRACKETS WITH (4) 3/8" X 1" BOLTS AND (4) 3/8" NYLOCK NUTS PER BRACKET (FIGURE 1.1). TORQUE ALL NUTS TO 20 FT-LB (FIGURE 1.2).

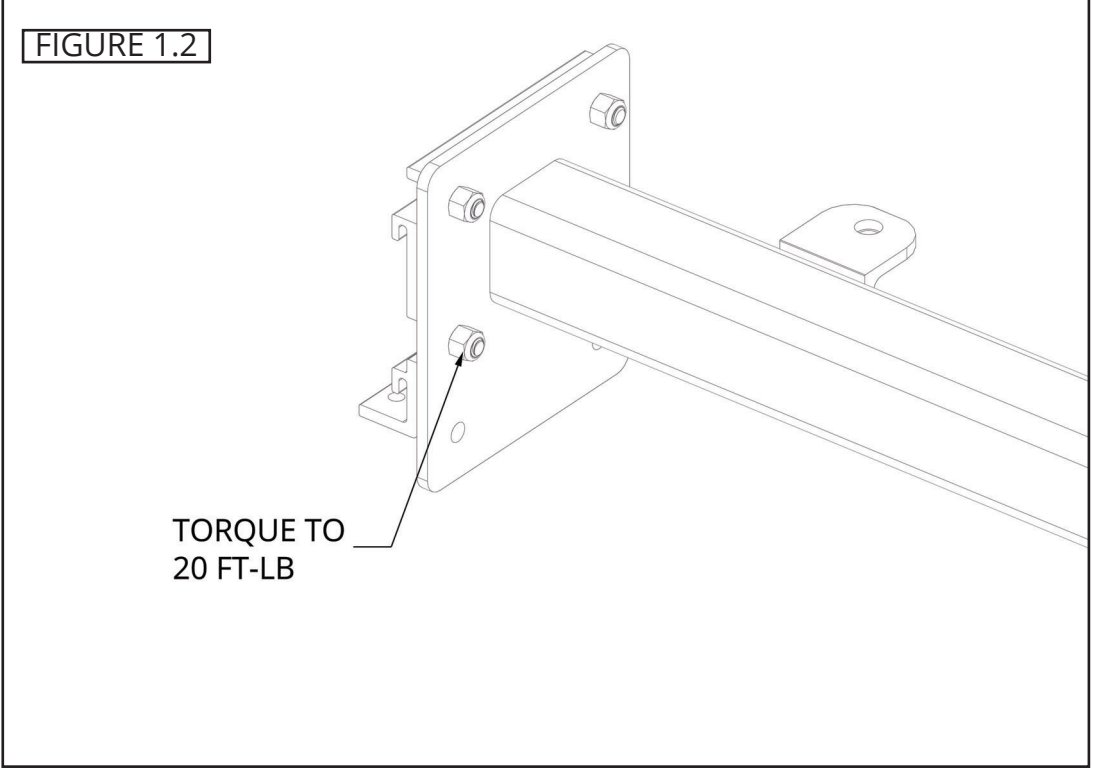
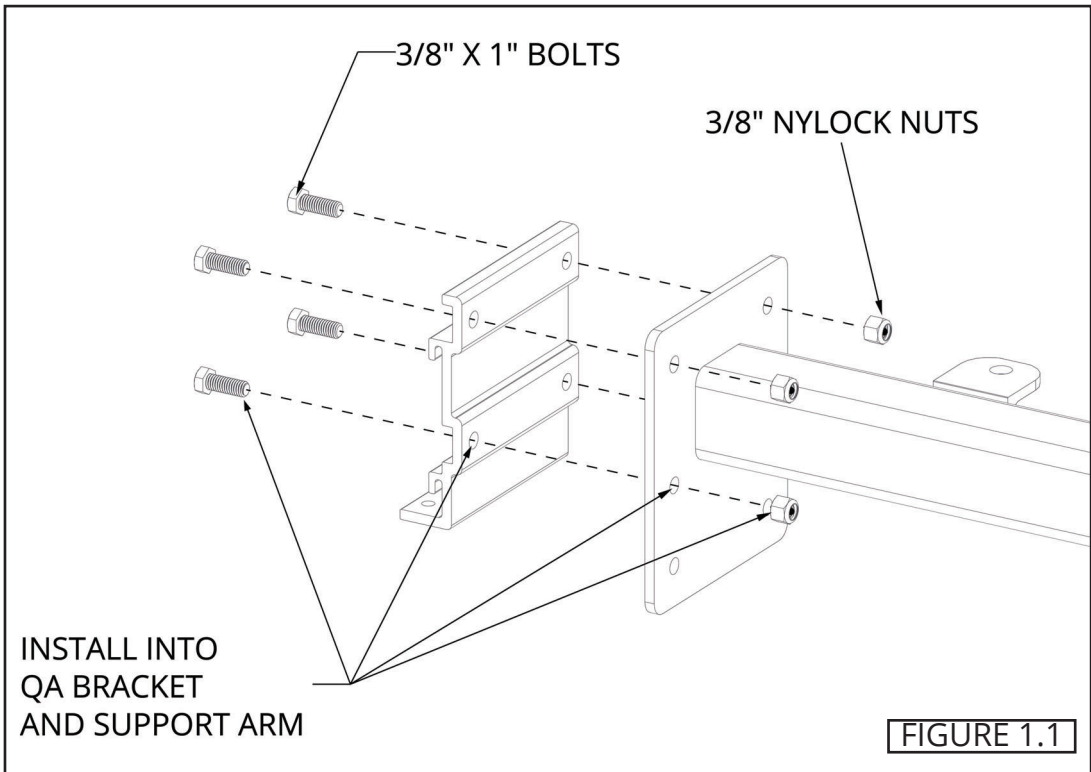

SET THE WIDTH AND DEPTH OF THE SUPPORT ARMS DETERMINED BY THE WIDTH AND DEPTH OF THE DOCK BOX (REFER TO DOCK BOX SUPPORT FRAME INSTRUCTIONS) (FIGURE 1.3). PLACE THE QUICK ATTACH BRACKETS ONTO THE DOCK SIDE AT THAT WIDTH (FIGURE 1.4).

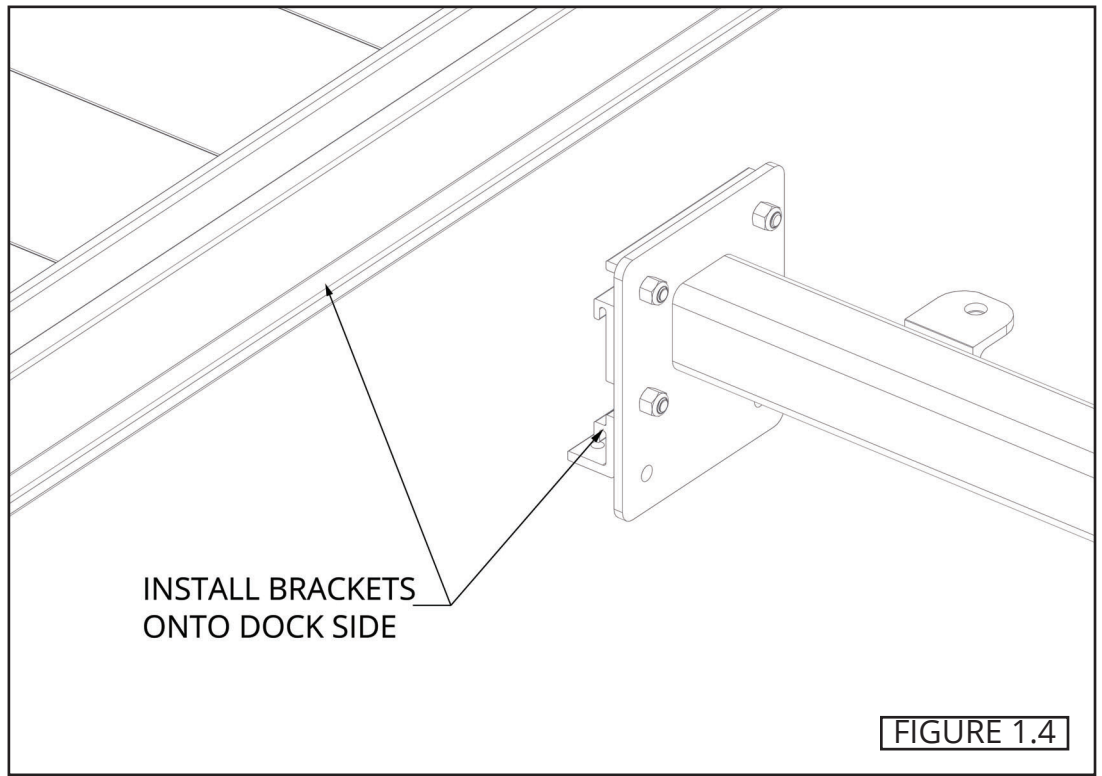
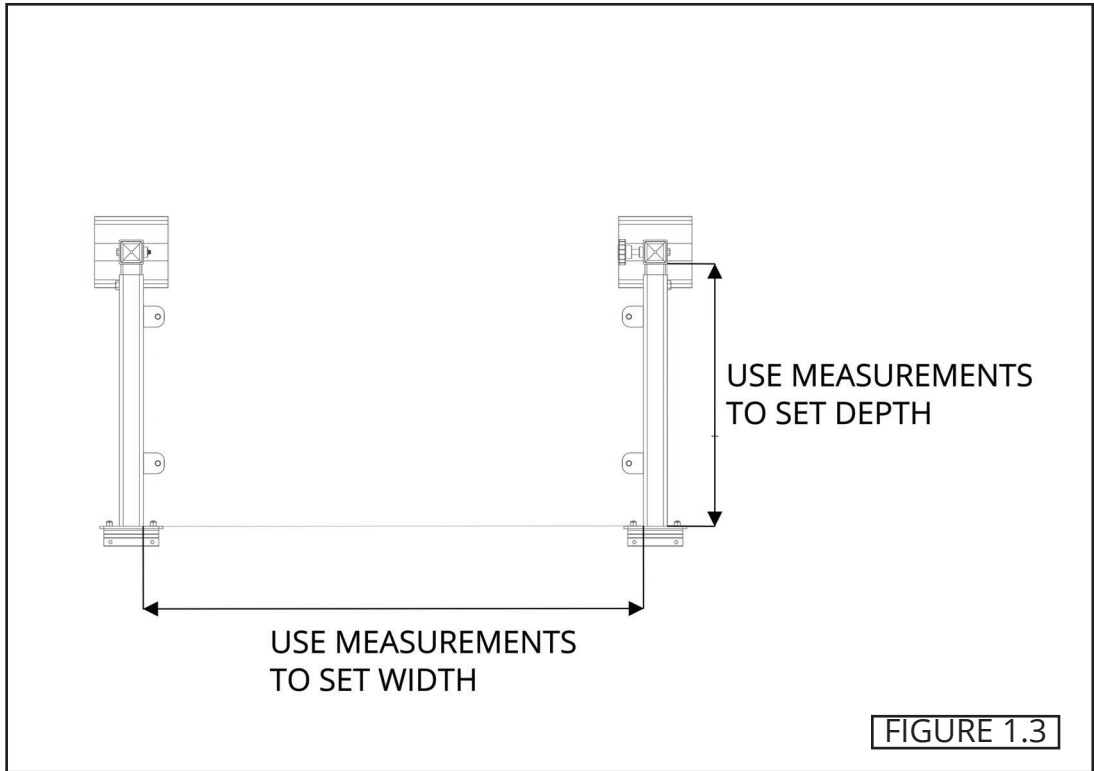

INSTALL (2) 3/8" X 1" BOLTS INTO THE BOTTOM OF EACH BRACKET (FIGURE 1.5). TORQUE TO 6 FT-LB MAXIMUM (FIGURE 1.6). REFER TO THE DOCK BOX SUPPORT FRAME INSTRUCTIONS TO COMPLETE INSTALLATION.

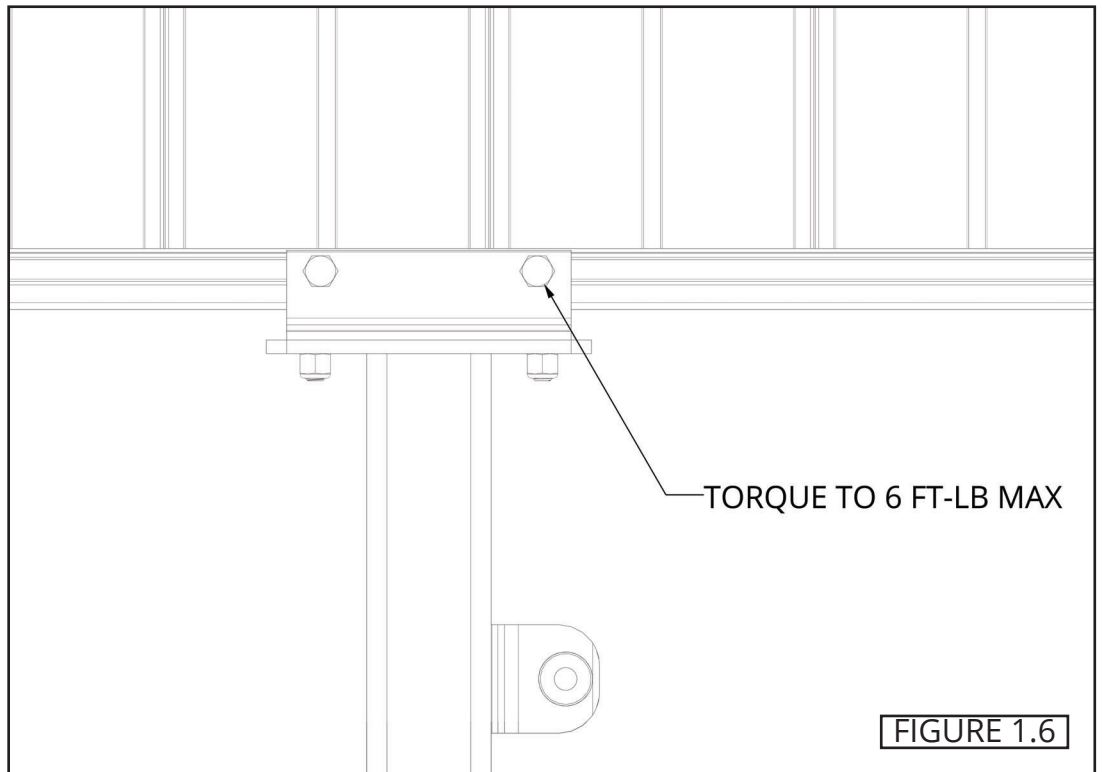
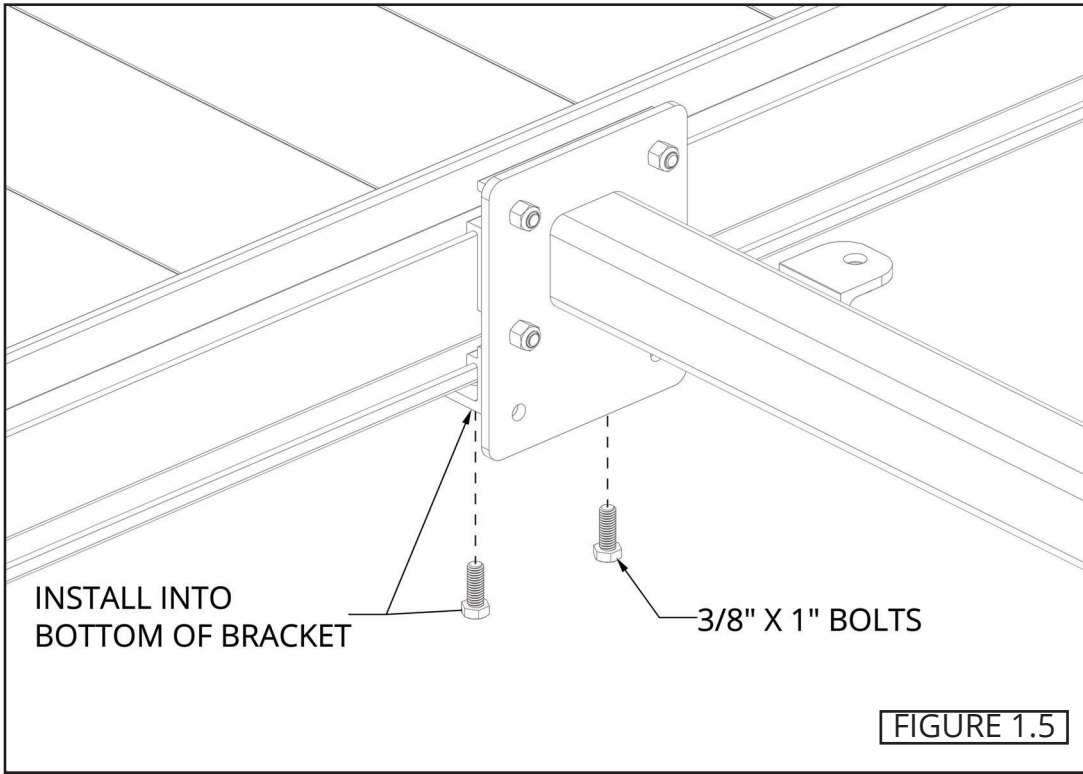

# **NOTES**

# **NOTES**



FLOE INTERNATIONAL, INC.  
48473 STATE HIGHWAY 65 • MCGREGOR, MN 55760  
[www.floeintl.com](http://www.floeintl.com)

*All material copyright © 2026 FLOE International, Inc.  
Specifications subject to change without notice.*