

FLOE DOCK MOUNTED ADJUSTABLE BOW STOP

ASSEMBLY INSTRUCTIONS

KIT P/N 511-00008-01

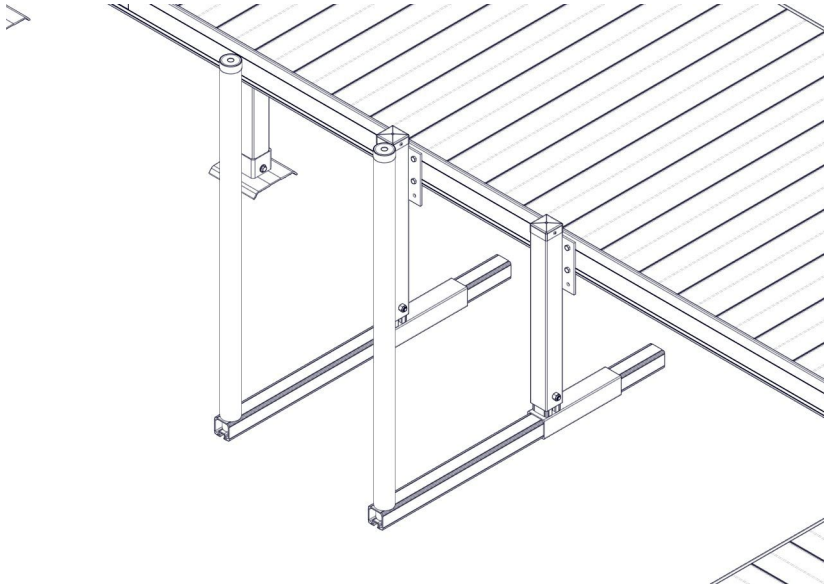

* DOCK NOT INCLUDED

NOTE:

ACCESSORY ATTACHMENT KITS ARE SOLD SEPARATELY FOR EACH DOCK (STANDARD ROLL-IN, QUICK ATTACH ROLL-IN, STANDARD SECTIONAL, QUICK ATTACH SECTIONAL, AND FLOATING). REFER TO THE INSTRUCTIONS INCLUDED WITH THE KIT.

TOOLS REQUIRED

- 3/4" SOCKET/WRENCH
- TAPE MEASURE
- TORQUE WRENCH
- MARKER

IMPORTANT NOTE:

CAUTION MUST BE USED WHEN PARKING A BOAT WITH THIS KIT INSTALLED. BOATS SHOULD BE DRIFTED INTO FINAL POSITION ON BOAT LIFT. FAILURE TO DO SO WILL RESULT IN DAMAGE TO BOAT, BOAT LIFT, AND/OR LIFT ACCESSORIES.

BILL OF MATERIALS/EXPLODED VIEW

P/N 511-00008-01		BOW STOP, ADJUSTABLE DOCK MOUNTED	
NO.	PART NUMBER	DESCRIPTION	QTY
1	001-70205-00	HHCS, 1/2-13 X 1" 18-8 SS	4
2	001-71021-00	FLAT WASHER, 1/2" 18-8 SS	4
3	001-76072-00	NUT, NYLOCK 1/2-13 ALUM.	4
4	010-00094-00	CAP, VINYL 2.375" ID X 1" - SMALL HOLE	2
5	011-01702-00	PIPE, 2" SCHED. 40 PVC X 48"	2
6	111-00518-00	WELD'T, ADJ. BOW STOP LOWER	2
7	111-00519-00	ASS'Y, ADJ. BOW STOP UPPER	2
8	111-00545-00	WELD'T, ADJ. BOW STOP CENTER	2

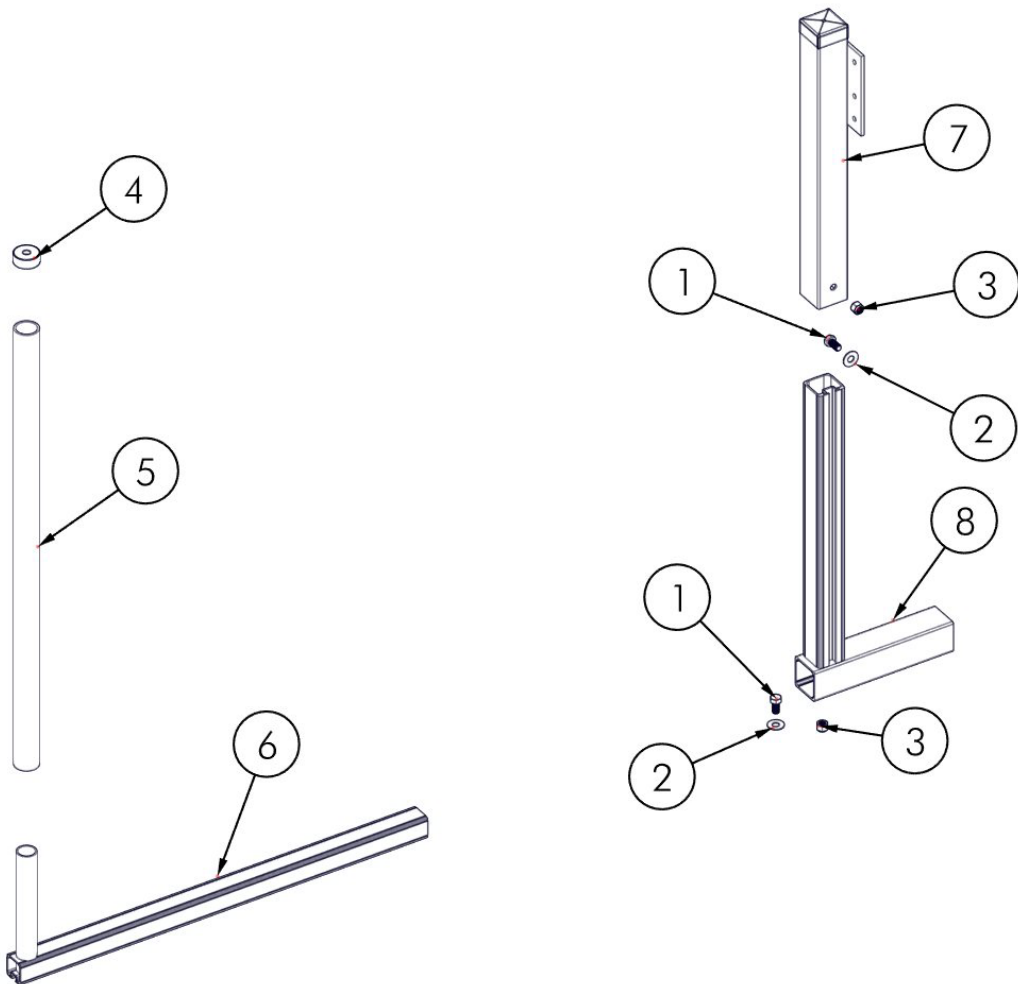

PRE-INSTALLATION

-UPRIGHT POSITIONING

THE BOW STOP UPRIGHTS SHOULD BE POSITIONED TO FULLY ENGAGE THE BOW WHEN THE BOAT IS POSITIONED CORRECTLY ON THE LIFT. THE PVC UPRIGHTS WILL BE VERTICAL AND AT THE FRONT OF THE BOW WHEN THE BOAT IS PARKED.

WHEN THE BOAT IS FLOATING IN THE PARKED POSITION IN THE LIFT, THE PVC UPRIGHTS SHOULD BE 6-8" ABOVE THE RUB RAIL.

IMPORTANT: THE PVC UPRIGHTS SHOULD NOT BE BENT FORWARD OR TOWARDS THE SIDES OF THE HULL.

EXAMPLES OF DIFFERENT HULL DESIGNS ARE SHOWN BELOW WITH RECOMMENDED UPRIGHT PLACEMENTS. SEE FOLLOWING PAGE ON HOW TO MEASURE FOR PLACEMENT.

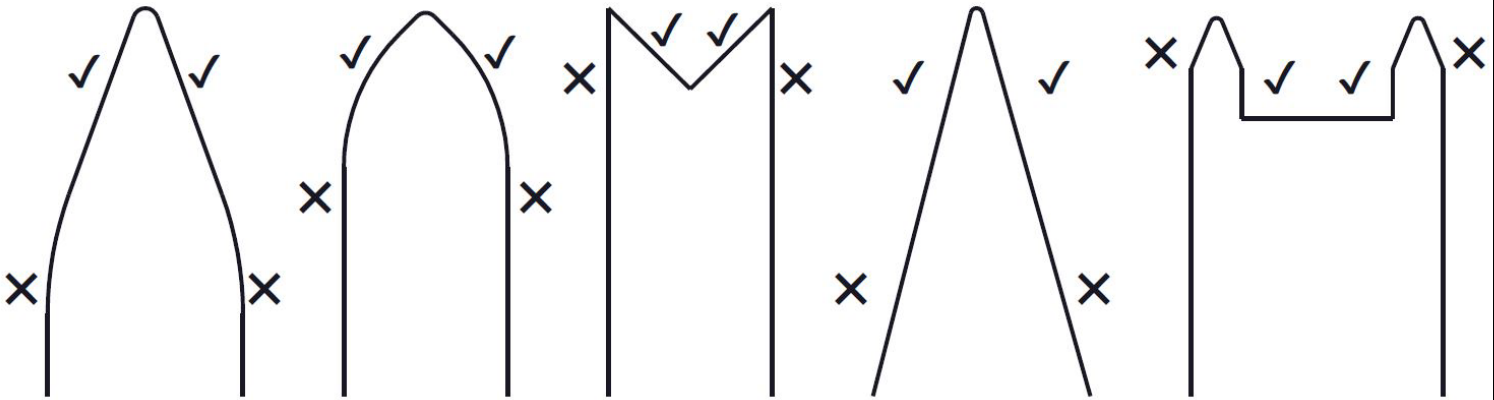

KEY

- ✓ CORRECT
- ✗ WRONG

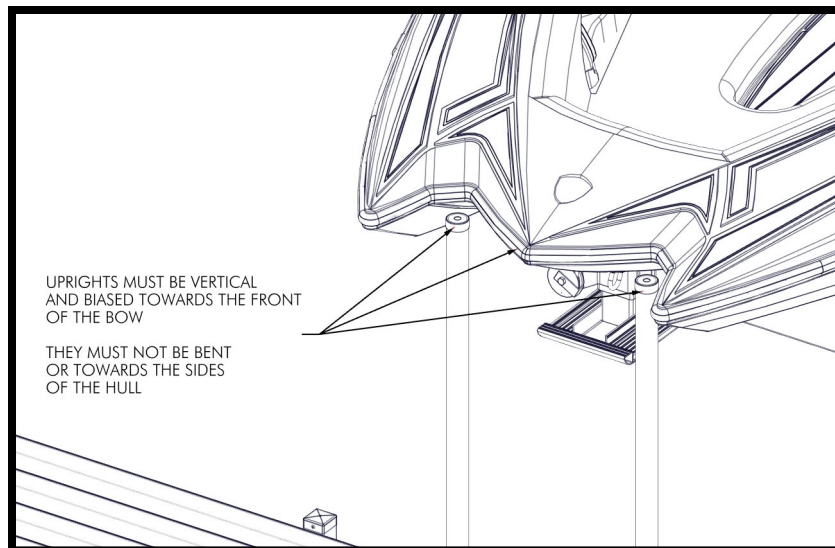

PRE-INSTALLATION

-DETERMINE LOCATION OF UPRIGHTS

TAKE A MEASUREMENT BETWEEN THE TWO APPROXIMATE LOCATIONS SHOWN IN THE EXAMPLE BELOW. ADD OR SUBTRACT 2" FROM THE MEASUREMENT "X" TO GET THE CENTER TO CENTER UPRIGHT PLACEMENT, DEPENDING ON THE STYLE OF BOAT. POSITION WILL VARY, BUT THE PVC UPRIGHTS SHOULD NOT BE BENT FORWARD OR TOWARDS THE SIDES OF THE HULL. THEY MUST REMAIN UPRIGHT.

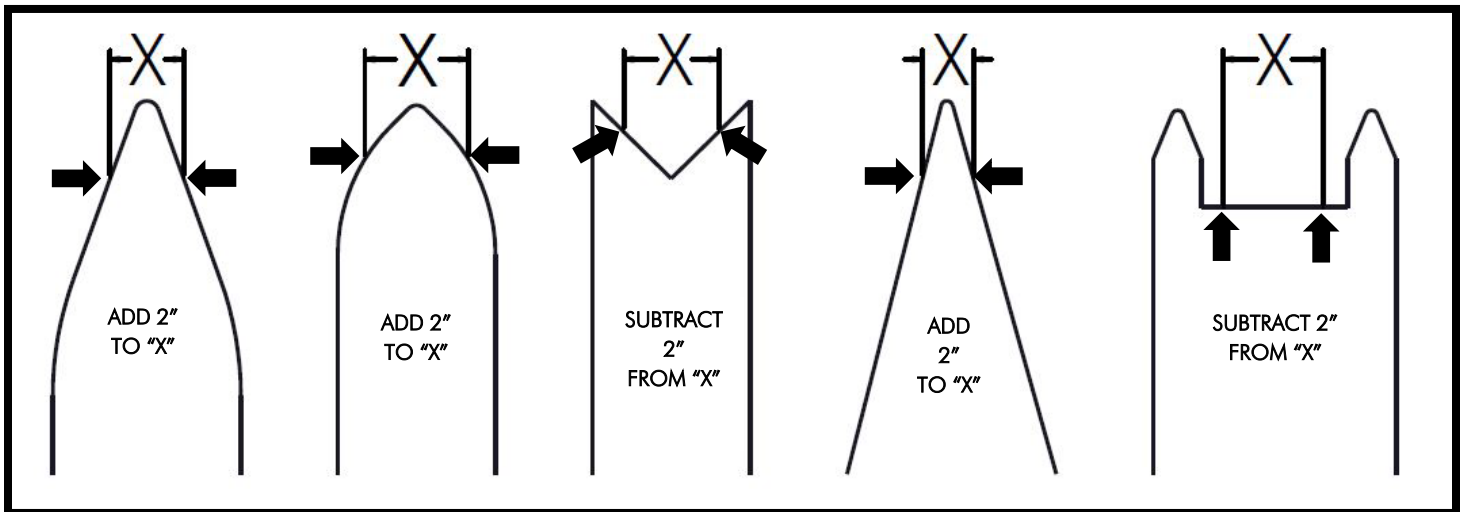

ASSEMBLY

STEP 1

PLACE (1) 1/2" X BOLT AND (1) 1/2" WASHER INTO THE UPPER MOUNT (FIGURE 1.1), SLIDE TUBE UPRIGHT WELDMENT INTO DOCK MOUNT (FIGURE 1.2).

FIGURE 1.1
2X

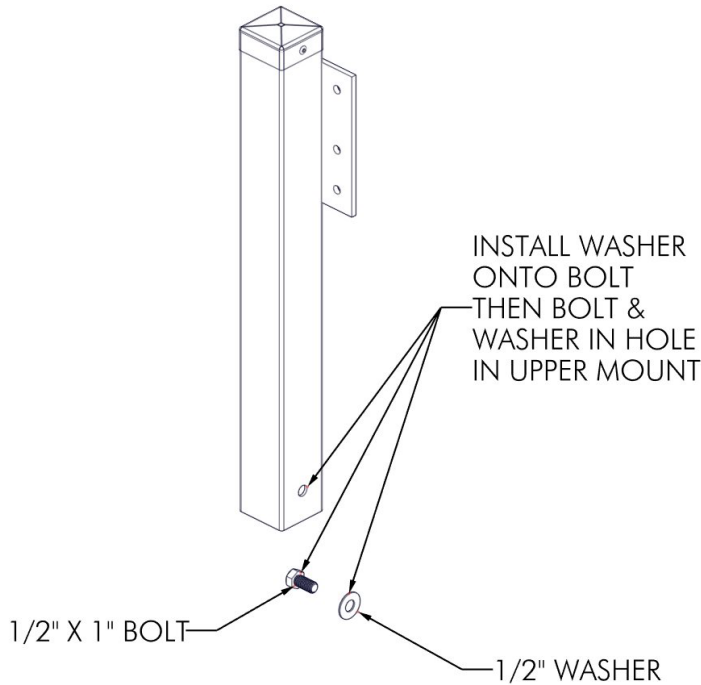

NOTE:
FOR SECTIONAL DOCKS, USE THE UPPER MOUNT AS A DRILL GUIDE BEFORE ASSEMBLING THE BOW STOP (SEE FIGURE 3.1)

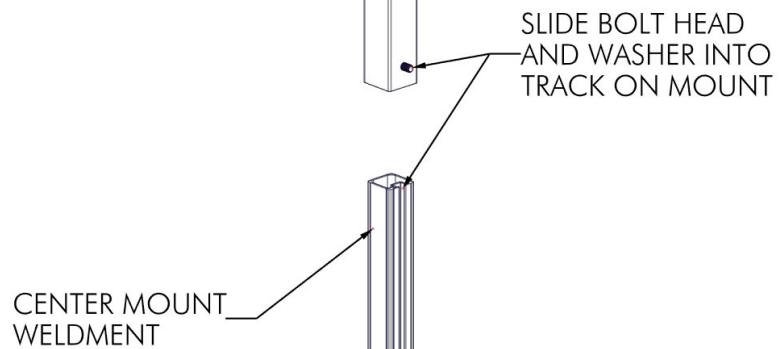

2X
FIGURE 1.2

PLACE A 1/2" NYLOCK NUT ONTO THE BOLT AND TIGHTEN TO SECURE THE CENTER MOUNT INTO THE UPPER MOUNT. NOTE: THE NUT MAY NEED TO BE LOOSENEED FOR ADJUSTING THE CENTER MOUNT UP OR DOWN (FIGURE 1.3). INSTALL A 1/2" X 1" BOLT WITH A 1/2" WASHER INTO THE HOLE IN THE CENTER MOUNT (FIGURE 1.4).

FIGURE 1.3

2X

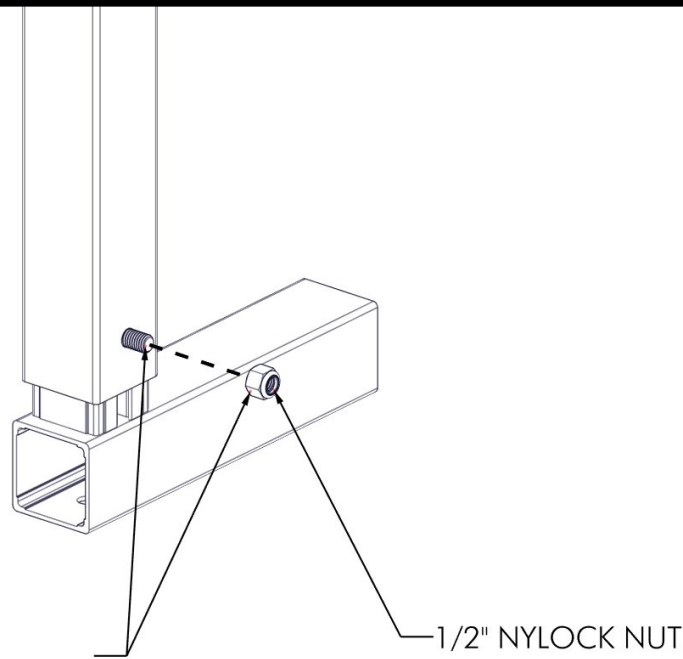

TIGHTEN TO SECURE INTO UPPER MOUNT

NUT MAY NEED TO BE LOOSENEED FOR ADJUSTMENT

FIGURE 1.4

2X

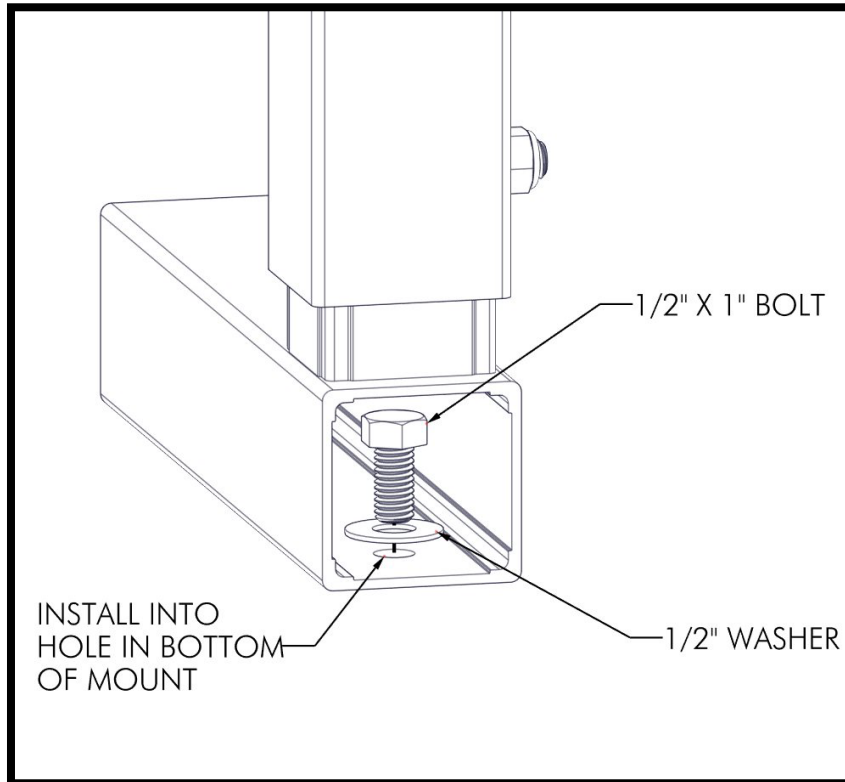

INSTALL INTO HOLE IN BOTTOM OF MOUNT

1/2" X 1" BOLT

1/2" WASHER

SLIDE THE LOWER MOUNT INTO THE CENTER MOUNT (FIGURE 1.5) WHILE ALIGNING THE BOLT AND WASHER INTO THE TRACK ON THE LOWER MOUNT (FIGURE 1.5A).

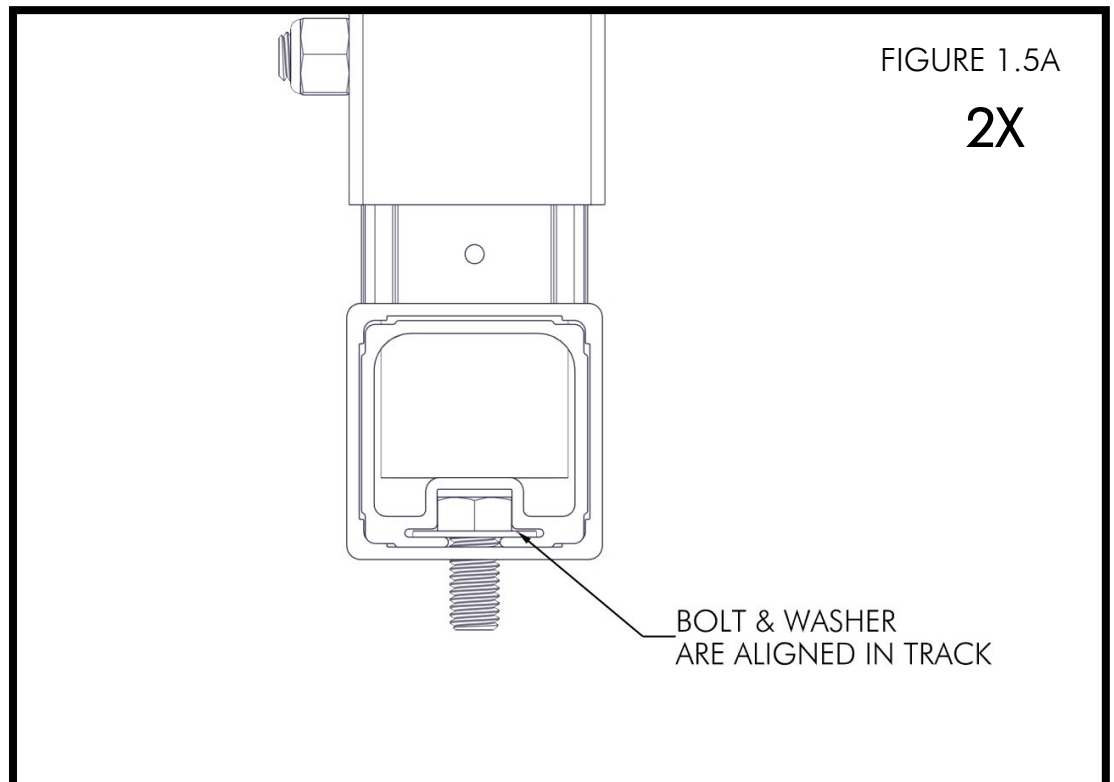
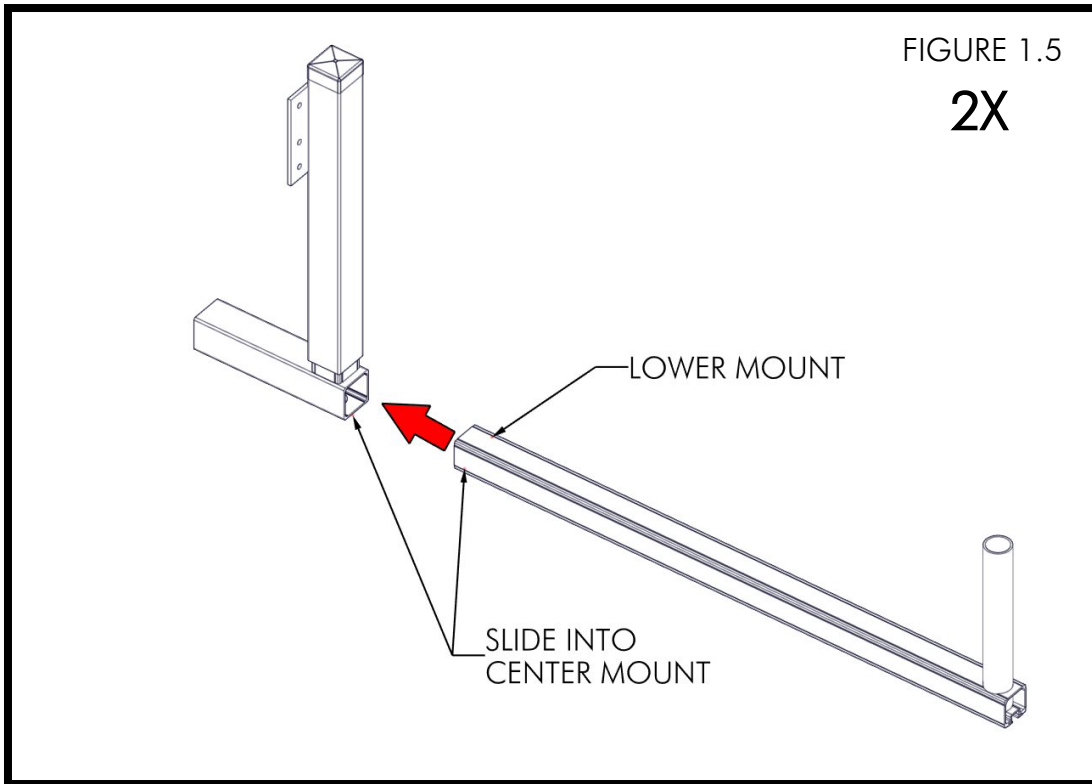

SECURE LOWER MOUNT TO CENTER MOUNT WITH A 1/2" NYLOCK NUT. DO NOT TIGHTEN AT THIS TIME, AS THE LOWER MOUNT MAY NEED TO SLIDE IN OR OUT FOR ITS FINAL INSTALLED LOCATION (FIGURE 1.6). INSTALL A VINYL CAP ONTO EACH PVC TUBE, THEN INSTALL THE TUBE ONTO THE UPRIGHT (FIGURE 1.7). **REFER TO THE ATTACHMENT KIT INSTRUCTIONS FOR INSTALLATION ONTO THE DOCK AND ADJUSTMENT OF THE BOW STOP.**

FIGURE 1.6

2X

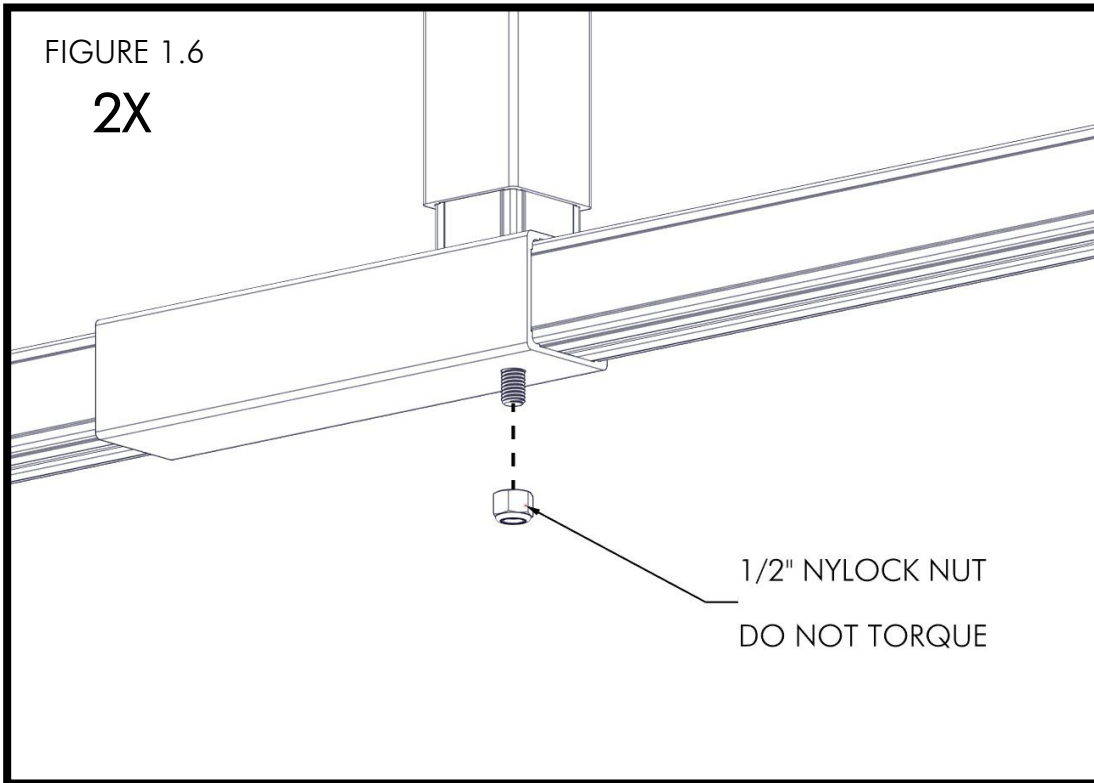

VINYL CAP

PVC UPRIGHT

PLACE CAP ON
TUBE, THEN SLIDE
TUBE ONTO UPRIGHT

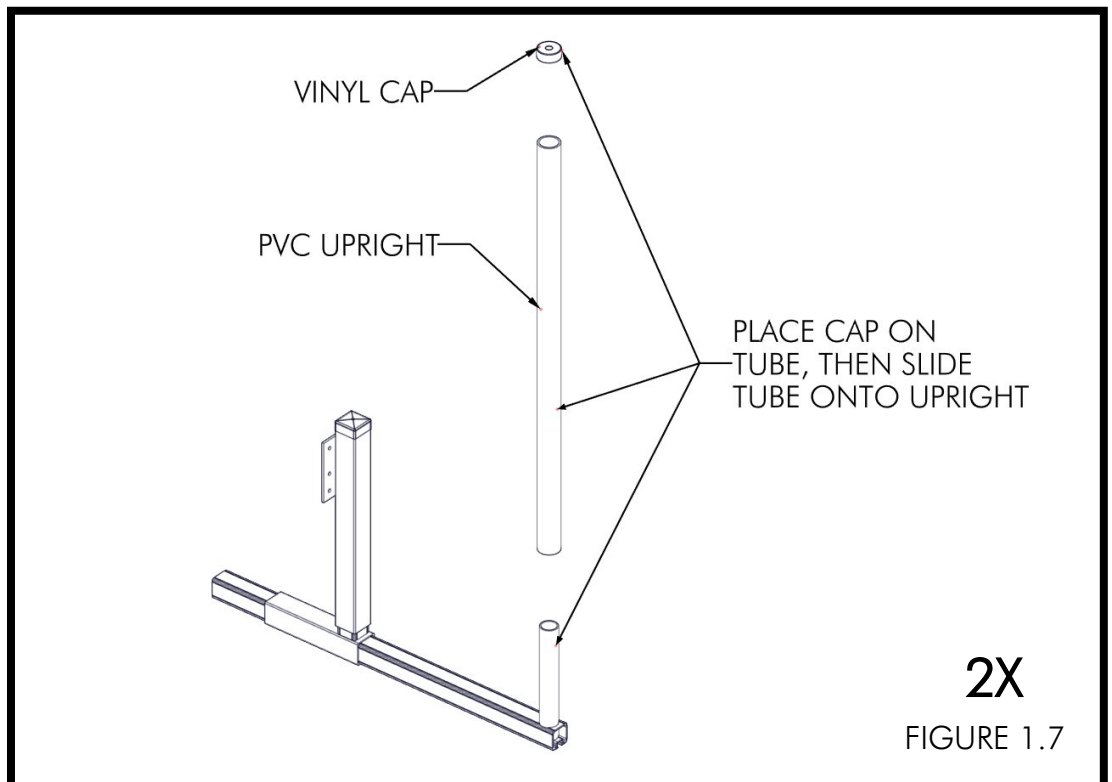

2X

FIGURE 1.7